

Cable Tray
Perforated / Solid

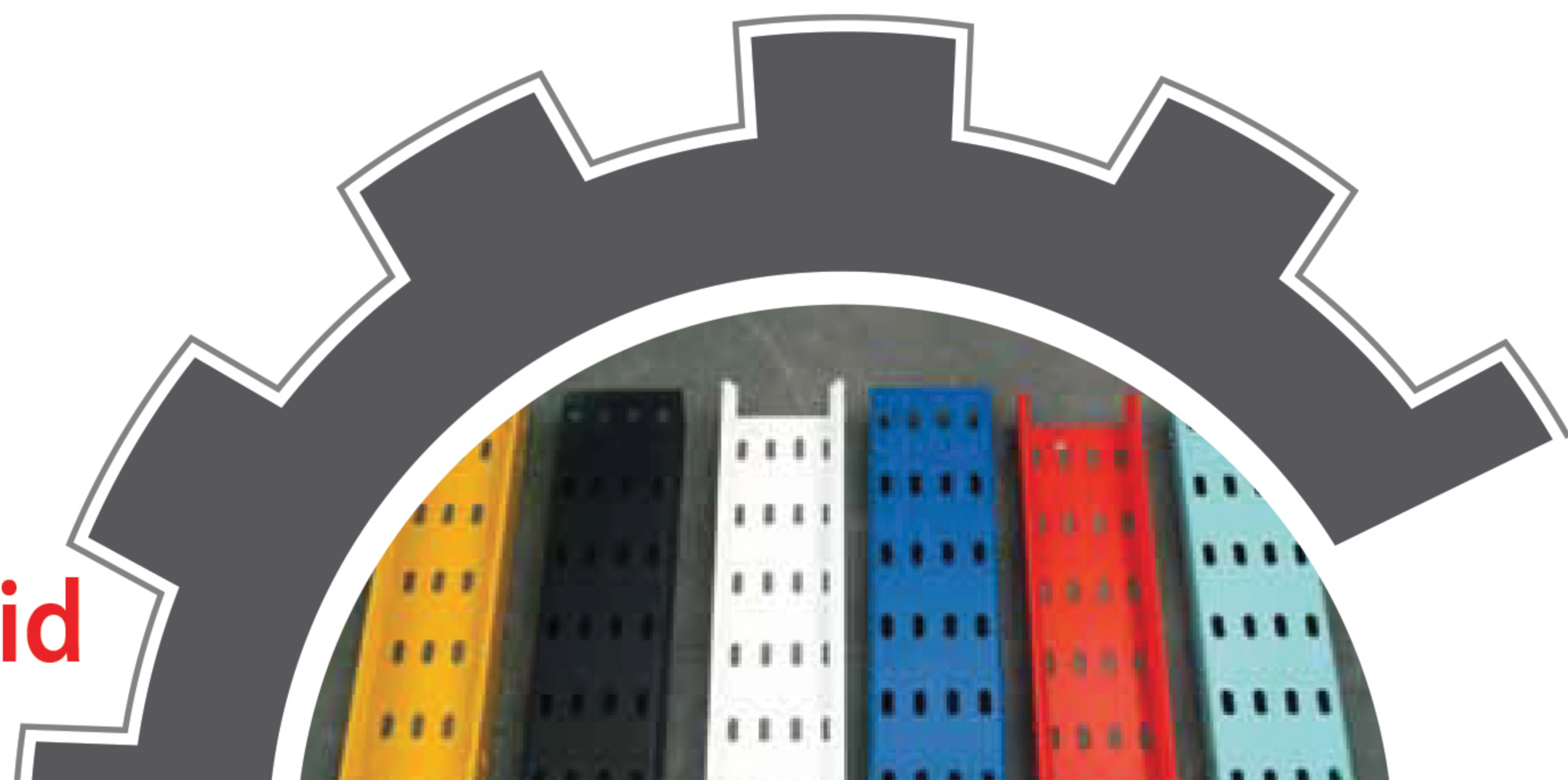

Fanavaran Industrial Group

www.t-fanavaran.com



گروه صنعتی فناوران

Fanavaran Industrial Group





INTRODUCTION

گروه صنعتی فناوران ارائه دهنده خدمات گسترده ای در زمینه های تولید و تأمین تجهیزات برق صنعتی نظیر انواع سینی و نردبان کابل، انواع لوله های فولادی برق، انواع جعبه تقسیم برق و دیگر محصولات در حوزه صنعت برق فعالیت خود را از سال ۱۳۸۷ آغاز نموده است.

این مجموعه تأمین کننده بخش عظیمی از درخواست های تجهیزات برق صنعتی برای شرکت های نفت و گاز، پتروشیمی، نیروگاهی و سایر صنایع در کشور می باشد.

مجموعه فناوران با استفاده از ماشین آلات و تجهیزات مدرن در منطقه صنعتی صالح آباد تهران واقع شده است. این کارگاه در زمینی به مساحت ۱۰۰۰ متر مربع واقع شده است که شامل دفتر کارگاه، محوطه مناسب برای ساخت و تولید انواع محصولات، کارگاه ماشین آلات، دستگاه CNC، دستگاه های خم کن، بخش جوشکاری و بخش کامپیوتری و برنامه نویسی می باشد. ضمن اینکه این کارگاه مجهز به جرثقیل سقفی برای جابجایی مواد و سایر خدمات نگهداری می باشد.

ما در این مجموعه همواره تلاش می کنیم تا محصولات قابل اعتماد، با کیفیت و اقتصادی را به مشتریان خود ارائه دهیم. همانطور که ما به ایجاد و تقویت همکاری خود ادامه می دهیم، به دنبال دستیابی رضایت ۱۰۰٪ مشتریان و جلب اعتماد آنها هستیم.

Fanavaran Industrial Group established in the year 1389, has been in the business offering a wide range of services in manufacture of Panels for various applications, Street Lighting Poles, Junction Boxes, Cable Trays & Accessories, Unistrut Channels, Wire mesh, Expanded metal, Profiled Sheets etc., for Oil & Gas, Petrochemical, Power and other major industries in IRAN. It is an ISO 2008 :9001, ISO 2004 :14001 & ISO 2007 :18001 Certified Company with standardization worked into all facets of its work.

Fanavaran manufacturing facility is located in Tehran Industrial Area with modern machineries and equipments. The workshop is located on 1000 Sq.mtrs of area which consists of Overhead Office, Stores and well laid down area for fabrication, machine shop, CNC Operation, Lighting Pole Machinery, Industrial blasting, Power coating plant, Hot-dip galvanization plant and computerized, manual & chemically etched engraving facilities. The workshop is equipped with overhead crane for material handling and other maintenance services.

We stride to provide reliable, highest quality and economic solutions to our customers. As we continue to build and strengthen our partnership, we are committed to achieve %100 customer satisfaction and earn your trust and loyalty.



CABLE TRAY - PERFORATED / SOLID TYPE

(ORDERING INFORMATION)

CODE	TYPE OF TRAY	
P	PERFORATED	
S	SOLID BOTTOM	
	CODE	RETURN FLANGE
	W	WITH RETURN FLANGE
	O	WITHOUT RETURN FLANGE
	CODE	HEIGHT OF TRAY
	A	40 MM
	B	80 MM
	C	100 MM
	D	120 MM
	E	150 MM
	CODE	THICKNESS
	J	1.0 MM
	K	1.25MM
	L	1.5 MM
	M	2.0 MM
	N	2.5 MM
	CODE	WIDTH OF TRAY
	* *	40MM - 1000MM
	CODE	LENGTH OF TRAY
	A	2000 MM
	B	3000 MM
	CODE	FINISH
	1	HOT DIP GALVANIZED
	2	PRE-GALVANIZED
	3	PAINTED / POWDER COATED
	4	STAINLESS STEEL

P W A L 300 B 1



CABLE TRAY - PERFORATED / SOLID TYPE

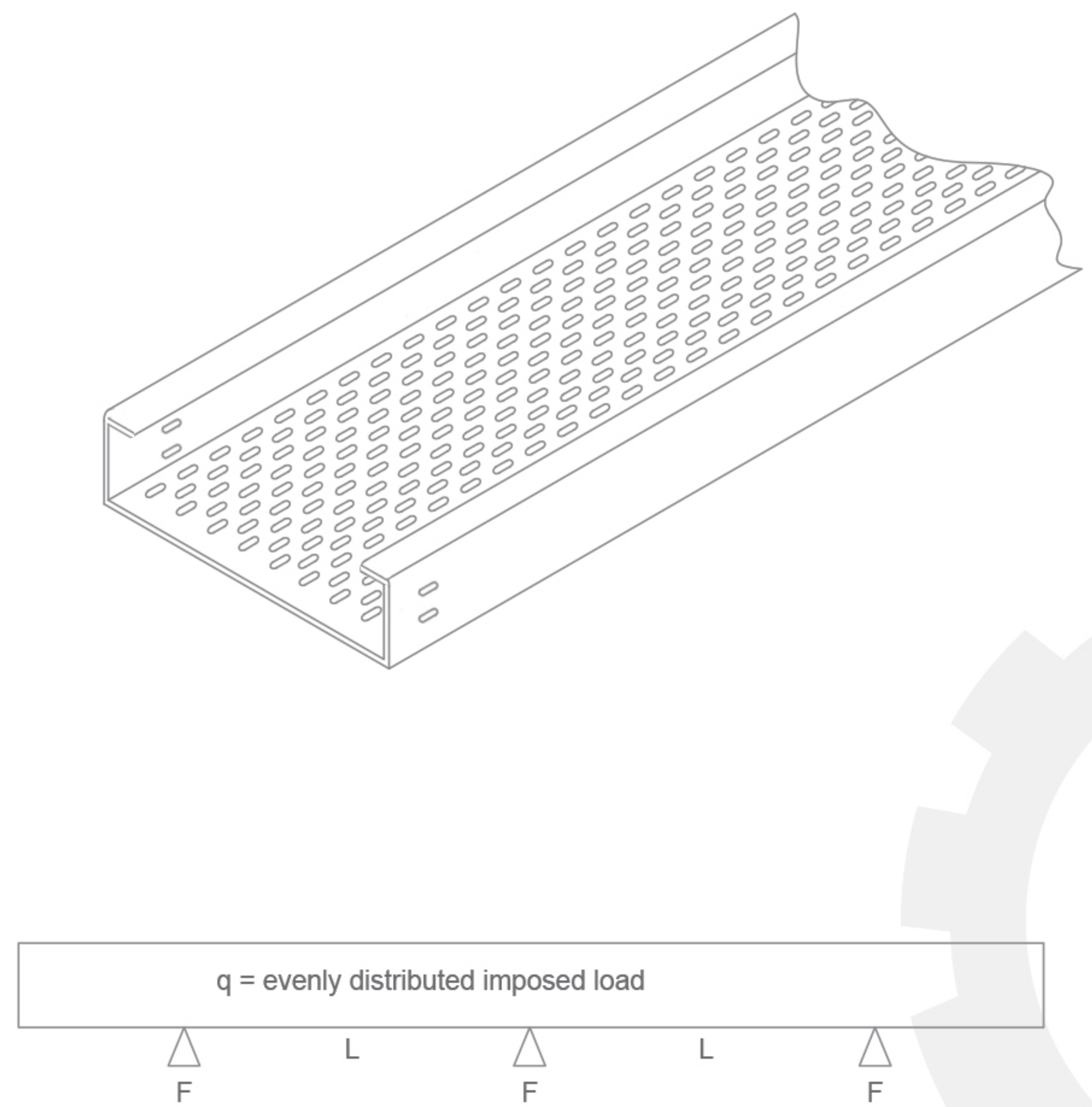
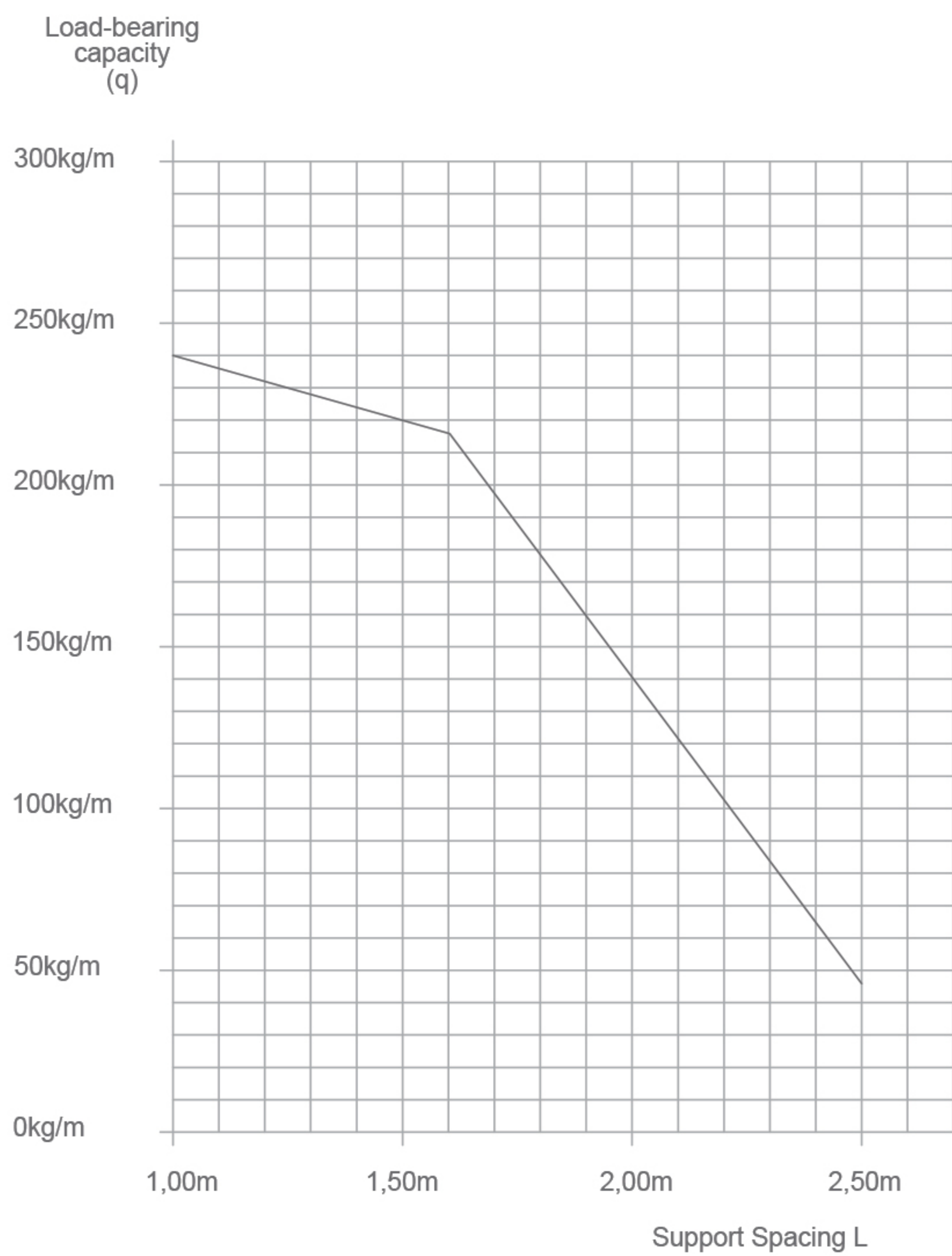

SUPPORT SPAN VS LOAD

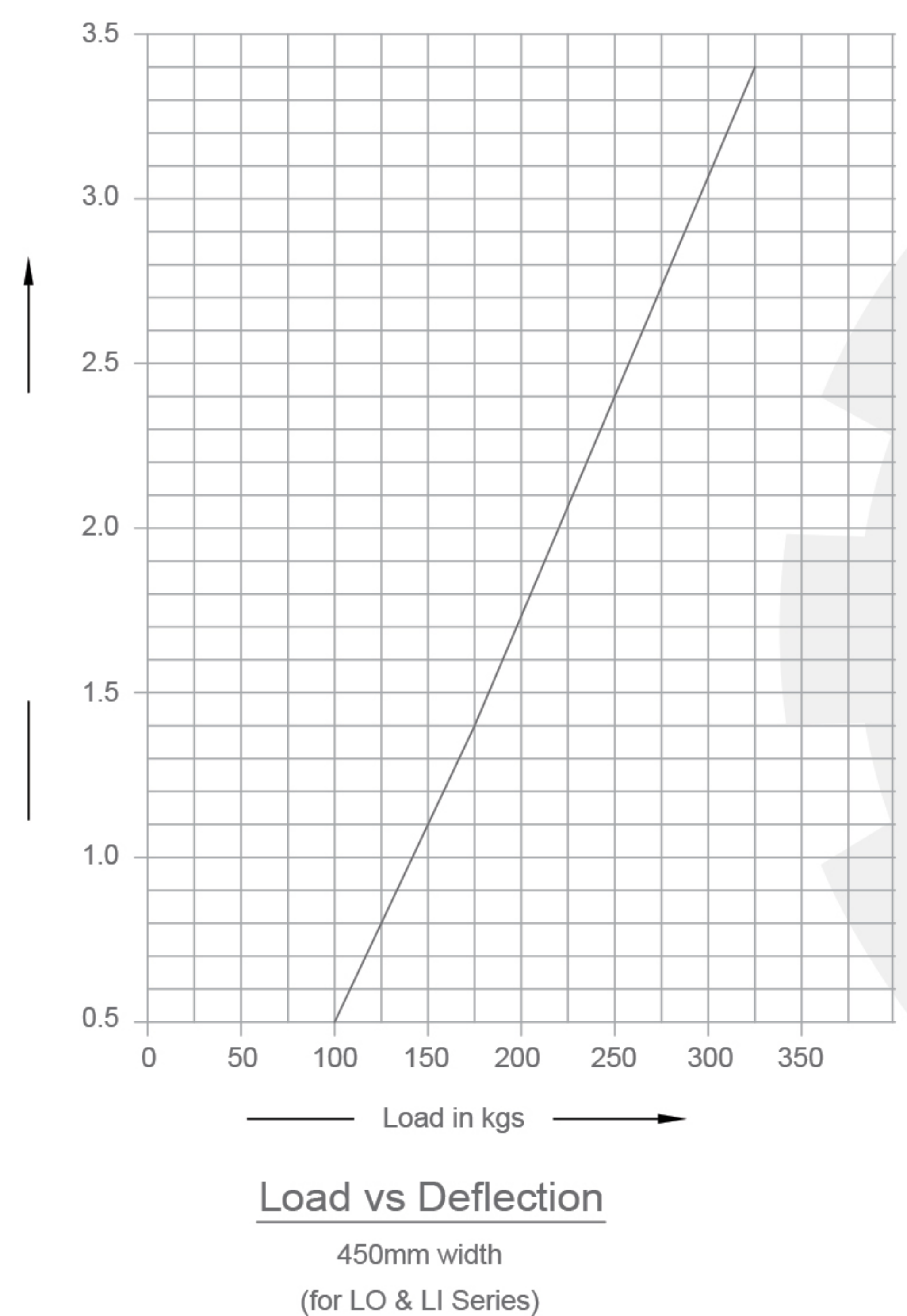
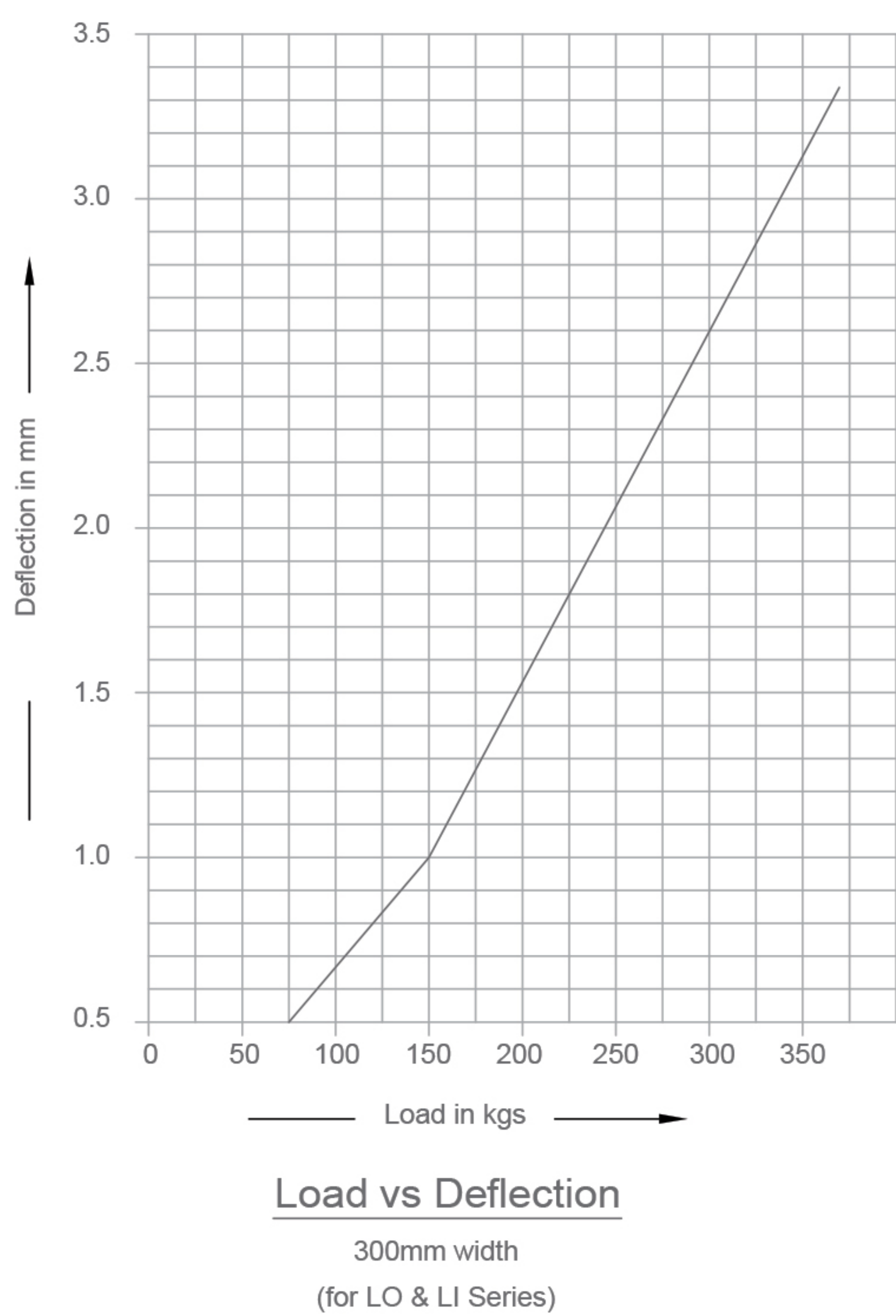

Fittings and hinged Connectors must be additionally reinforced and supported at the immediate joint for the load-bearing capacity indices!

Cover Panels the permissible load-bearing capacity is reduced when using Cover Panels by their "meter weight"

Foot Traffic Cable Trays may not be walked upon, and avoid lateral loads as leaning ladders!



CABLE TRAY - PERFORATED / SOLID TYPE

PERFORATED CABLE TRAY

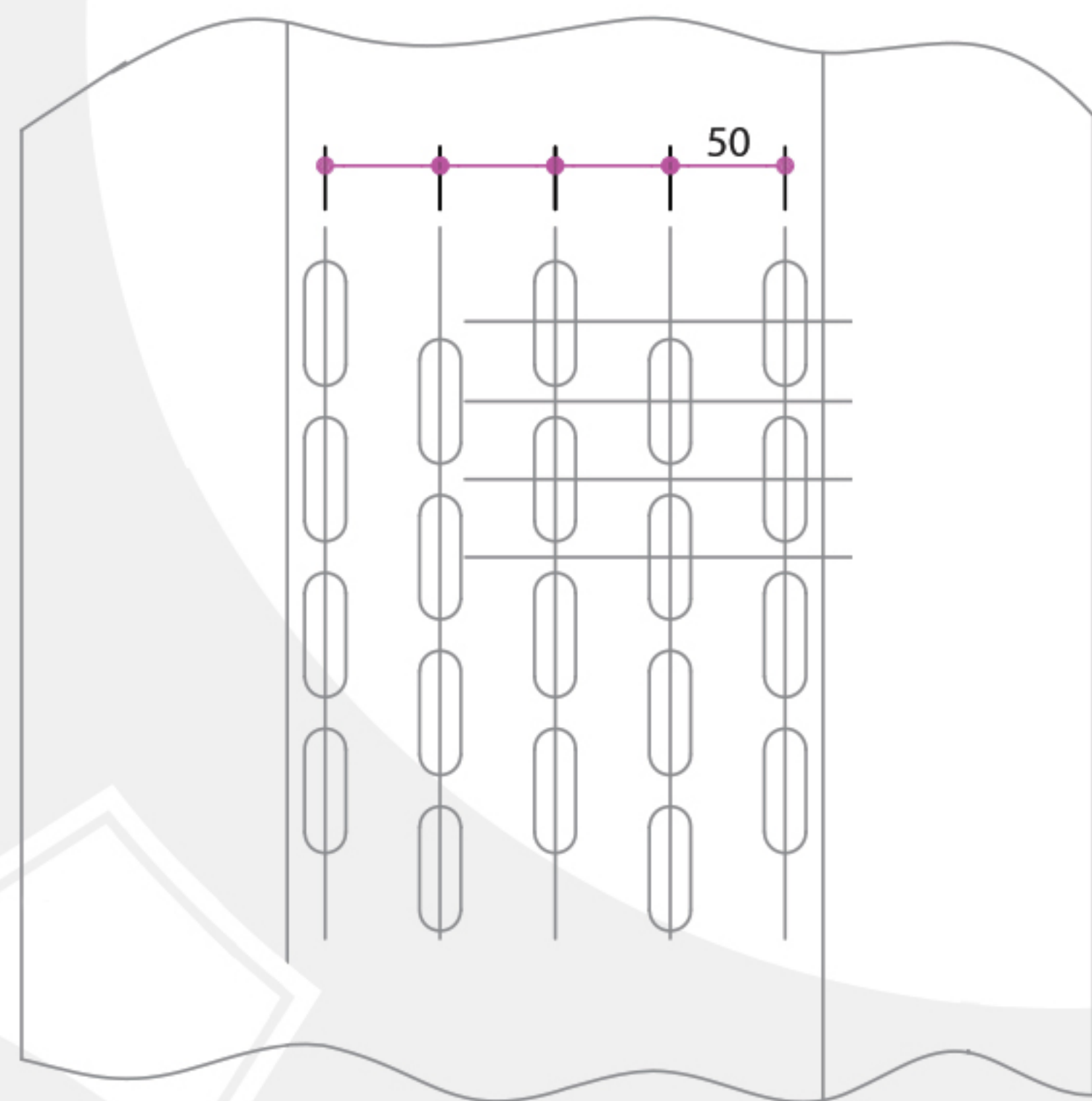
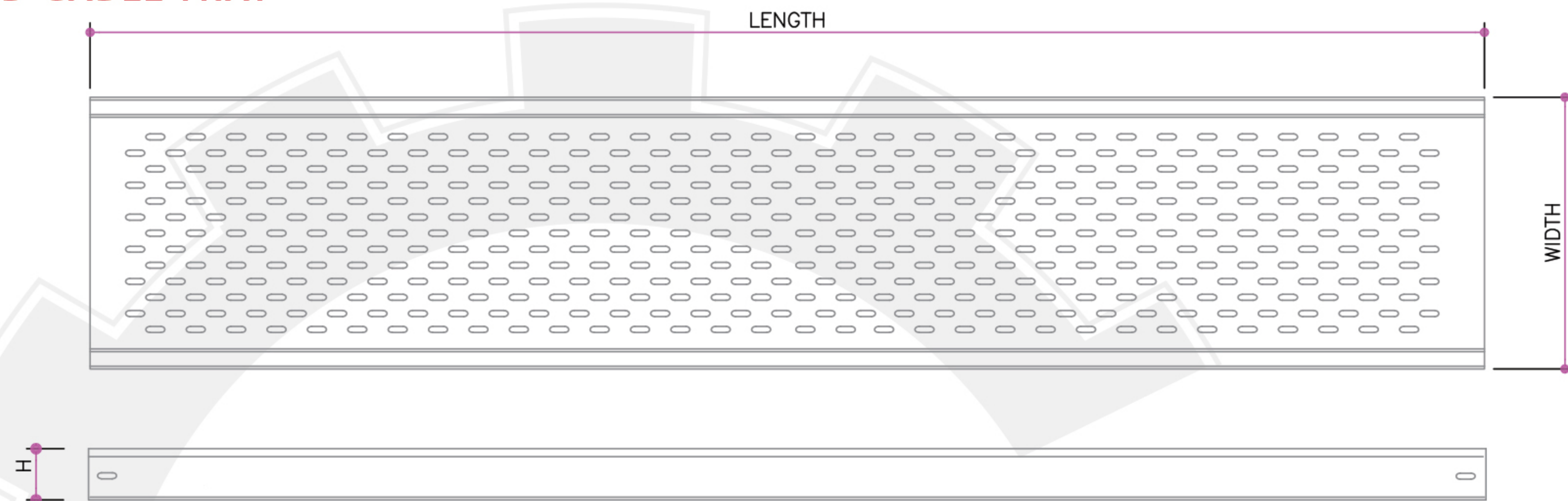

CABLE TRAY - PERFORATION TYPE

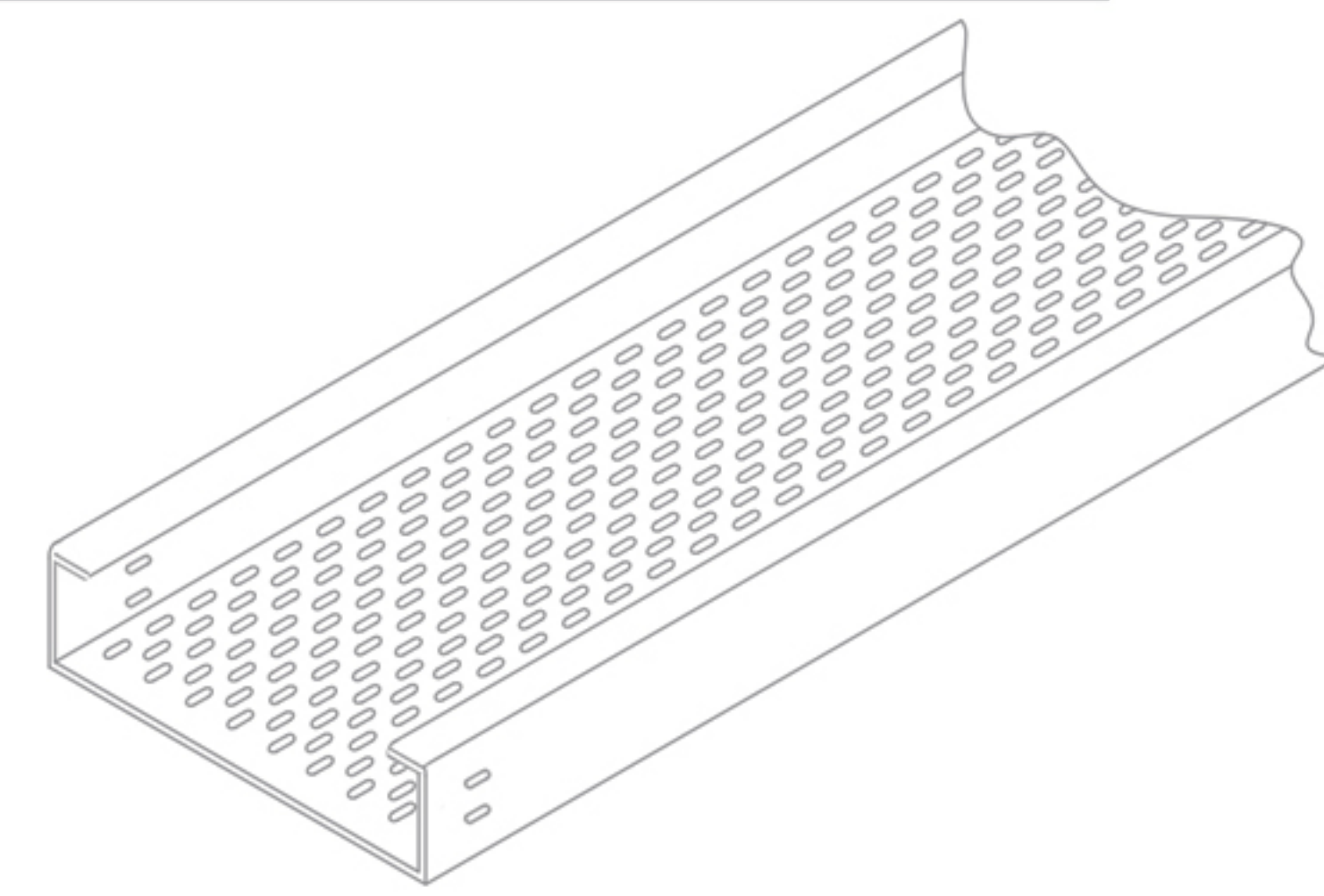

CABLE TRAY - WITH RETURN FLANGE

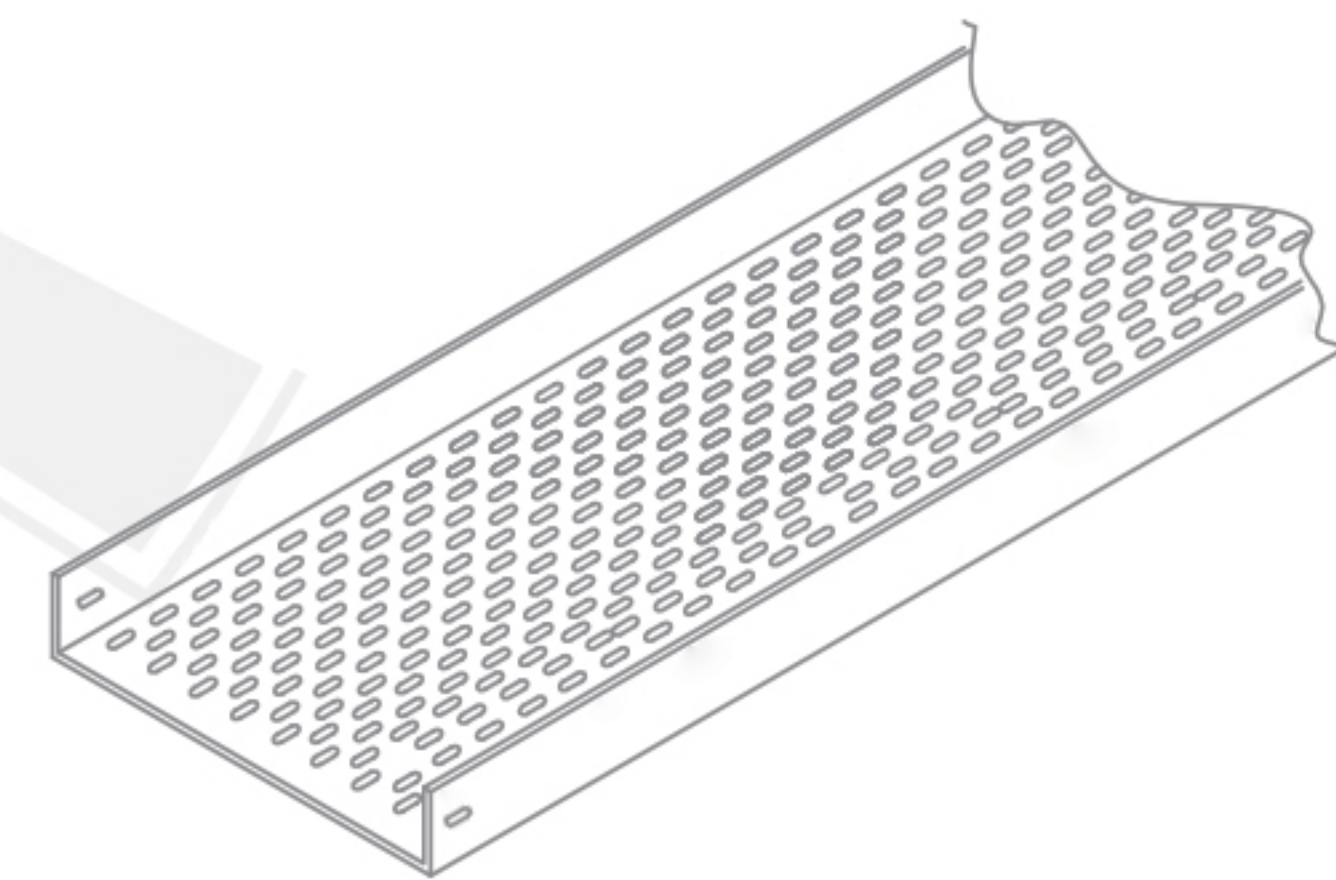

CABLE TRAY - WITHOUT RETURN FLANGE

SOLID BOTTOM CABLE TRAY

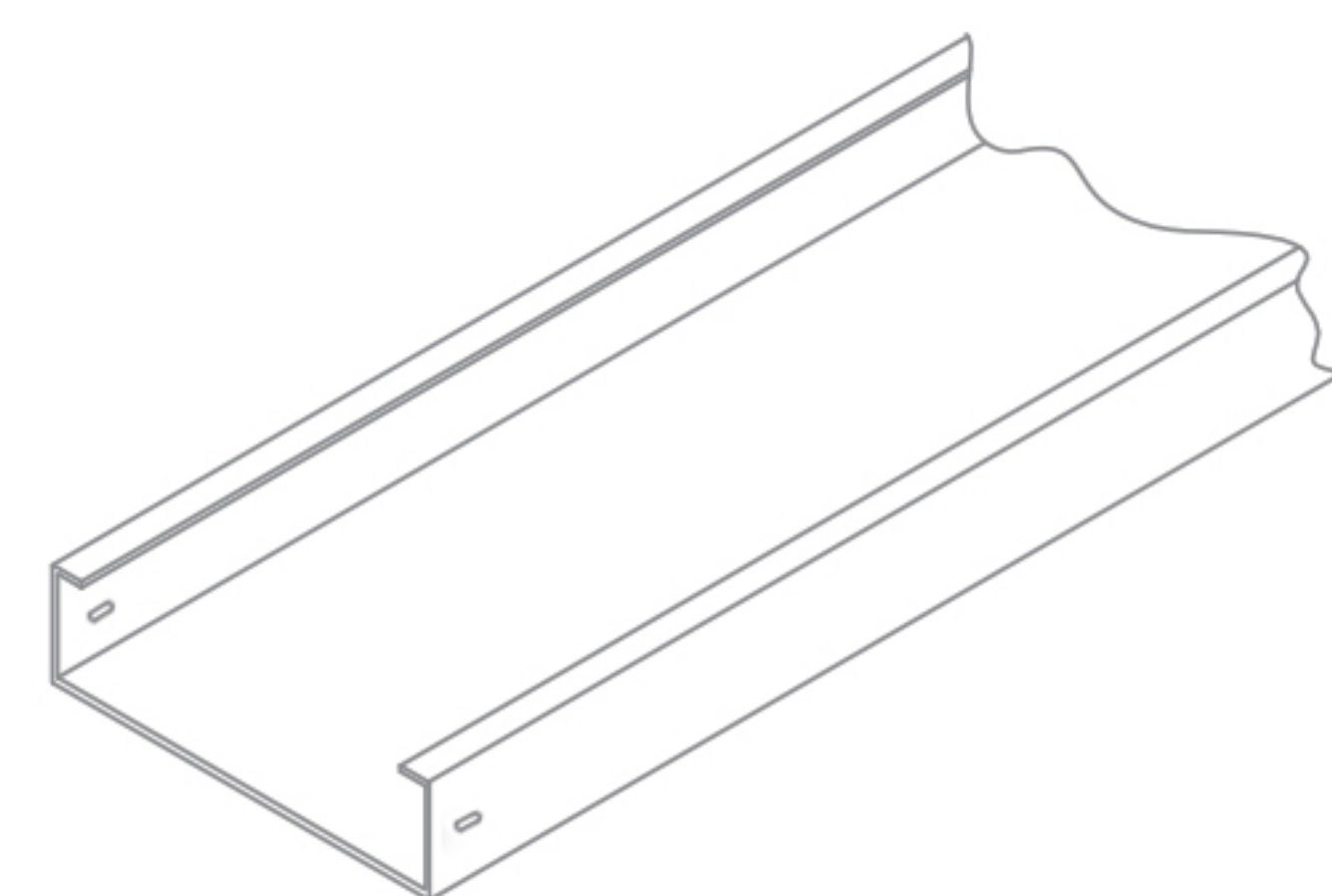

CABLE TRAY - SOLID BOTTOM WITH FLANGE

All Dimensions are in mm



CABLE TRAY - PERFORATED / SOLID TYPE FITTINGS & COVERS

90° VERTICAL ELBOW-INSIDE

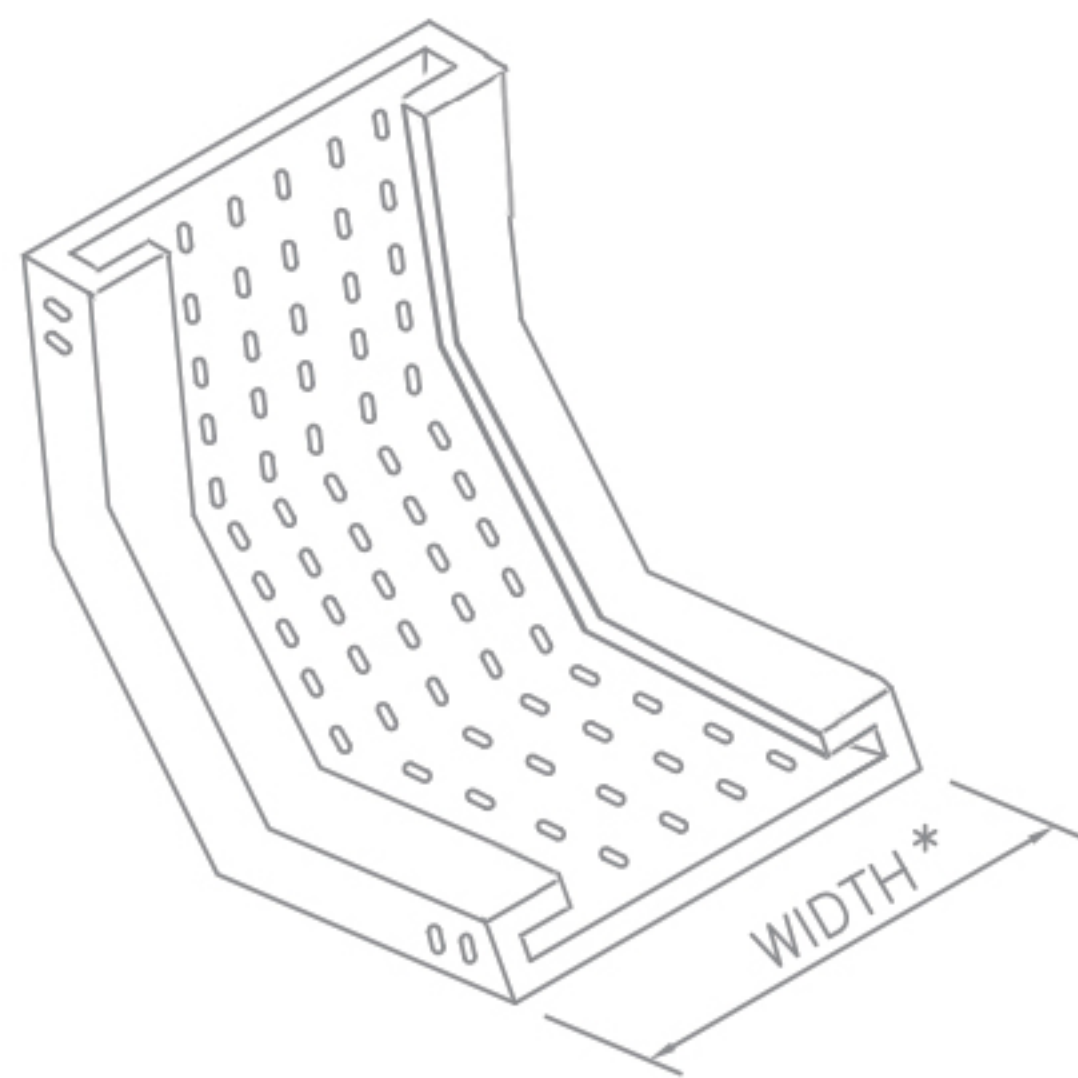

PERFORATED TYPE

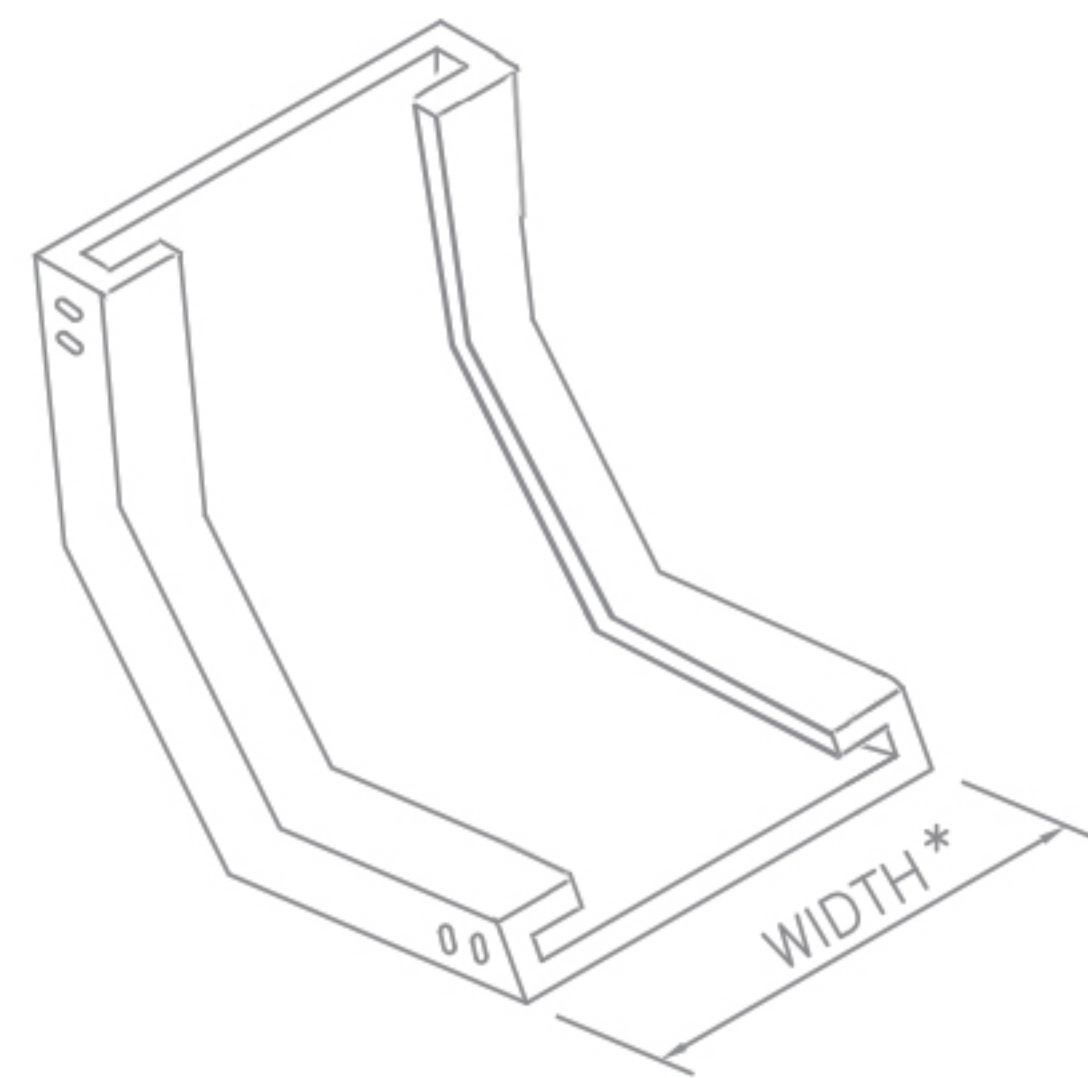

SOLID BOTTOM TYPE

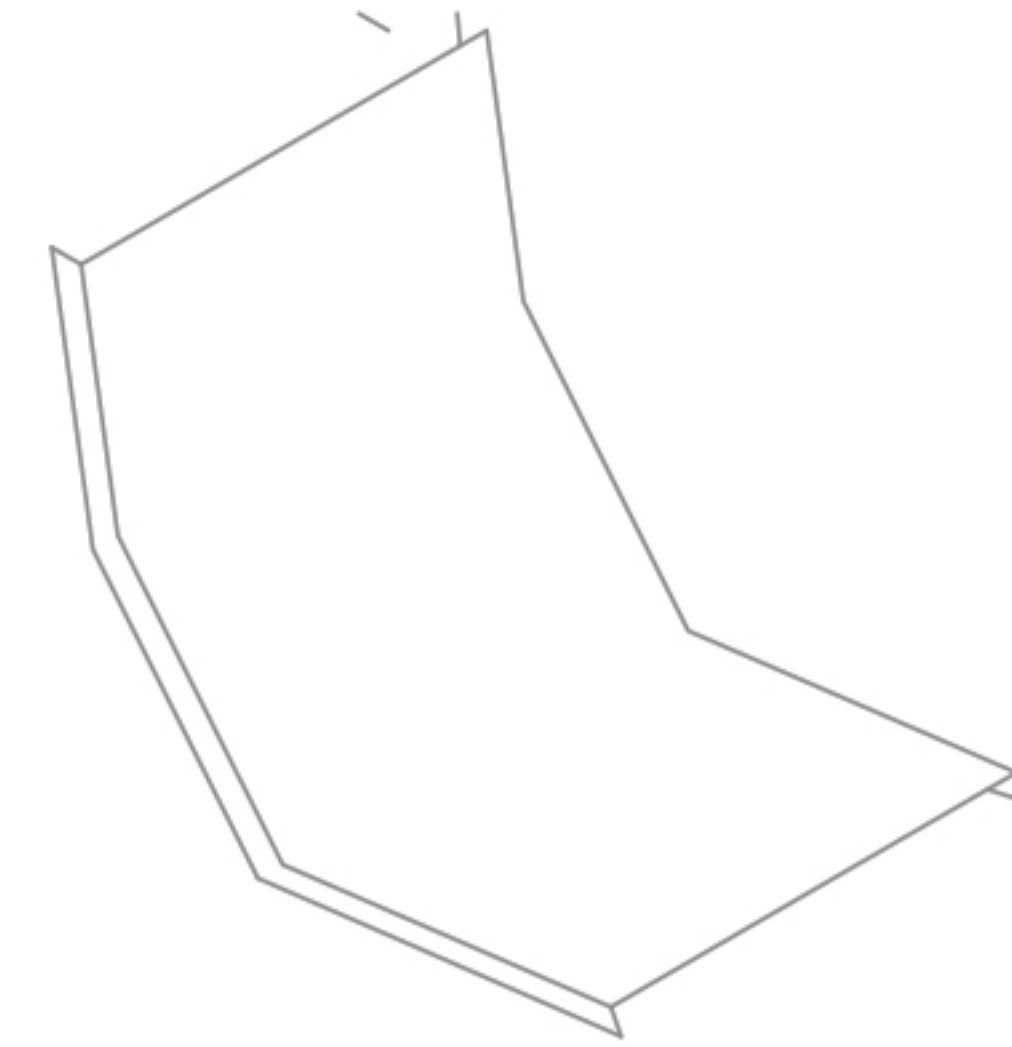
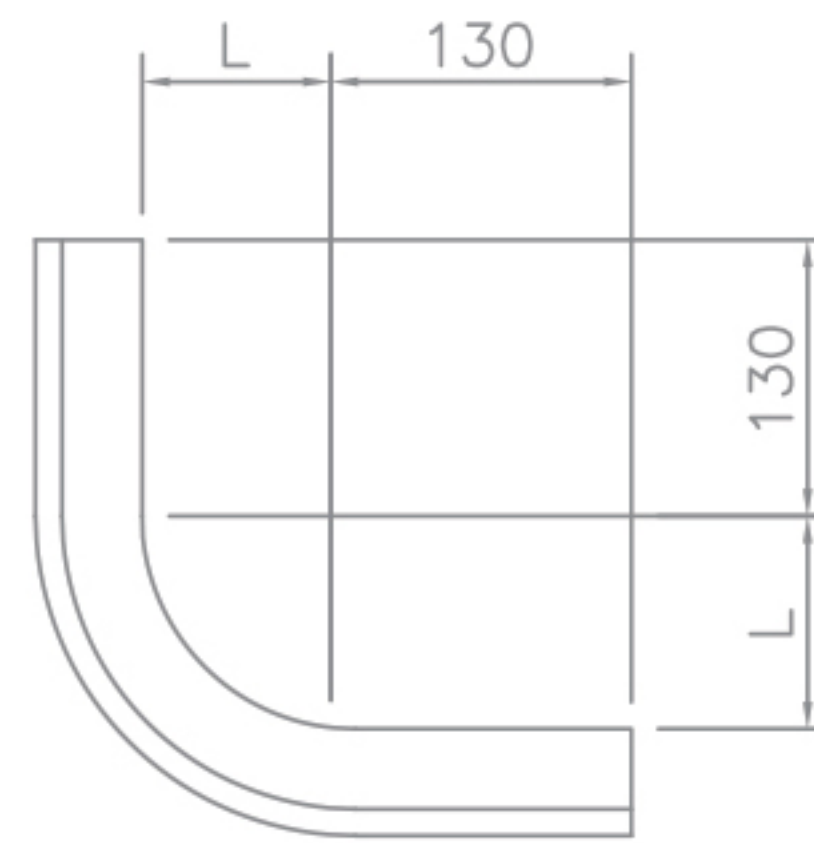

COVER

(Unit : mm)

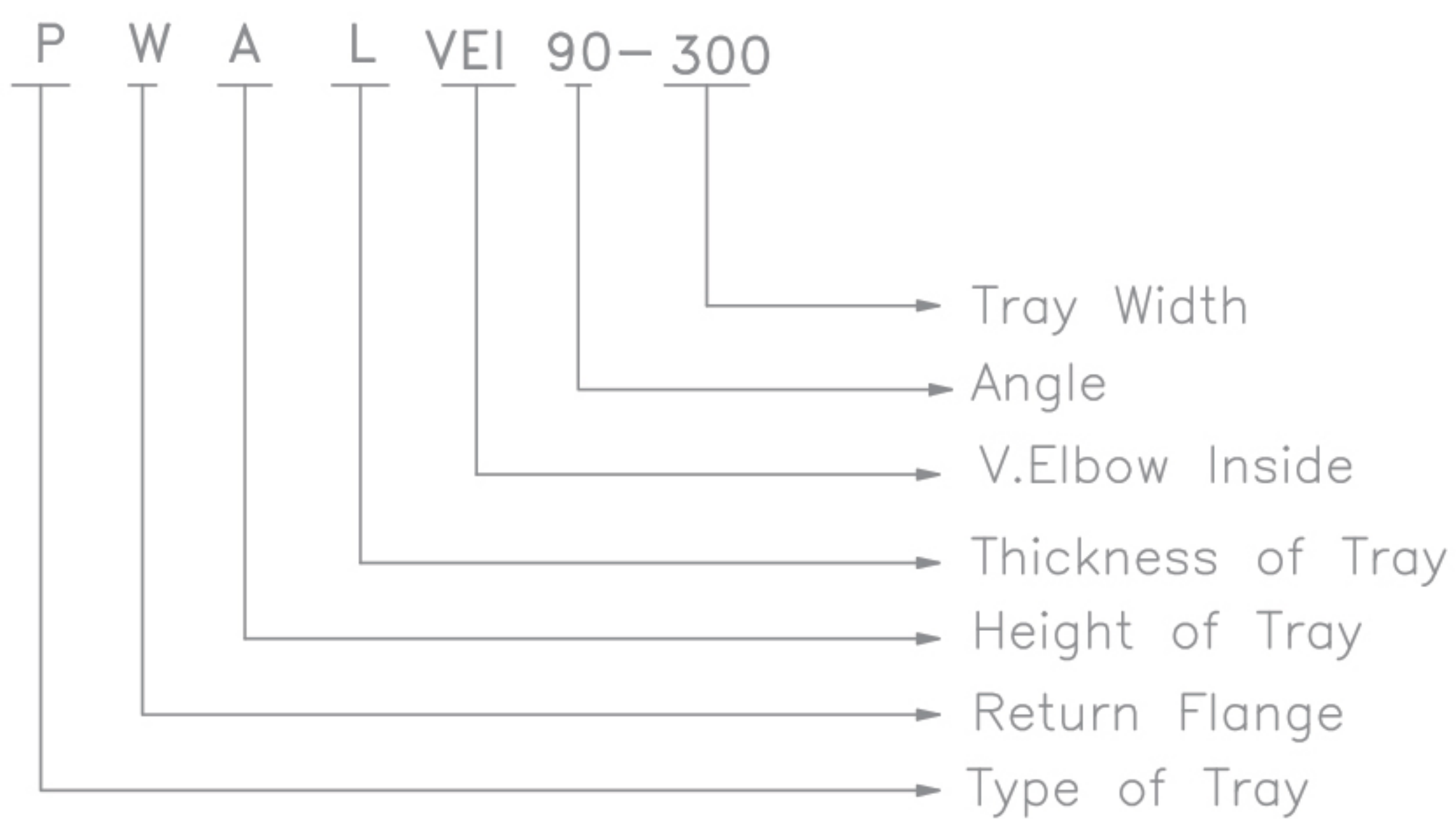

Cat.No.	Tray Width	L	Cover Width	Section
PWALVEI90 - 50	50	170	60	 TRAY
PWALVEI90 - 100	100	170	110	
PWALVEI90 - 150	150	170	160	
PWALVEI90 - 200	200	170	210	
PWALVEI90 - 250	250	170	260	
PWALVEI90 - 300	300	170	310	 TRAY
PWALVEI90 - 350	350	170	360	
PWALVEI90 - 400	400	170	410	
PWALVEI90 - 500	500	170	510	 COVER
PWALVEI90 - 600	600	170	610	
PWALVEI90 - 750	750	170	760	
PWALVEI90 - 900	900	170	910	

90° VERTICAL ELBOW-OUTSIDE

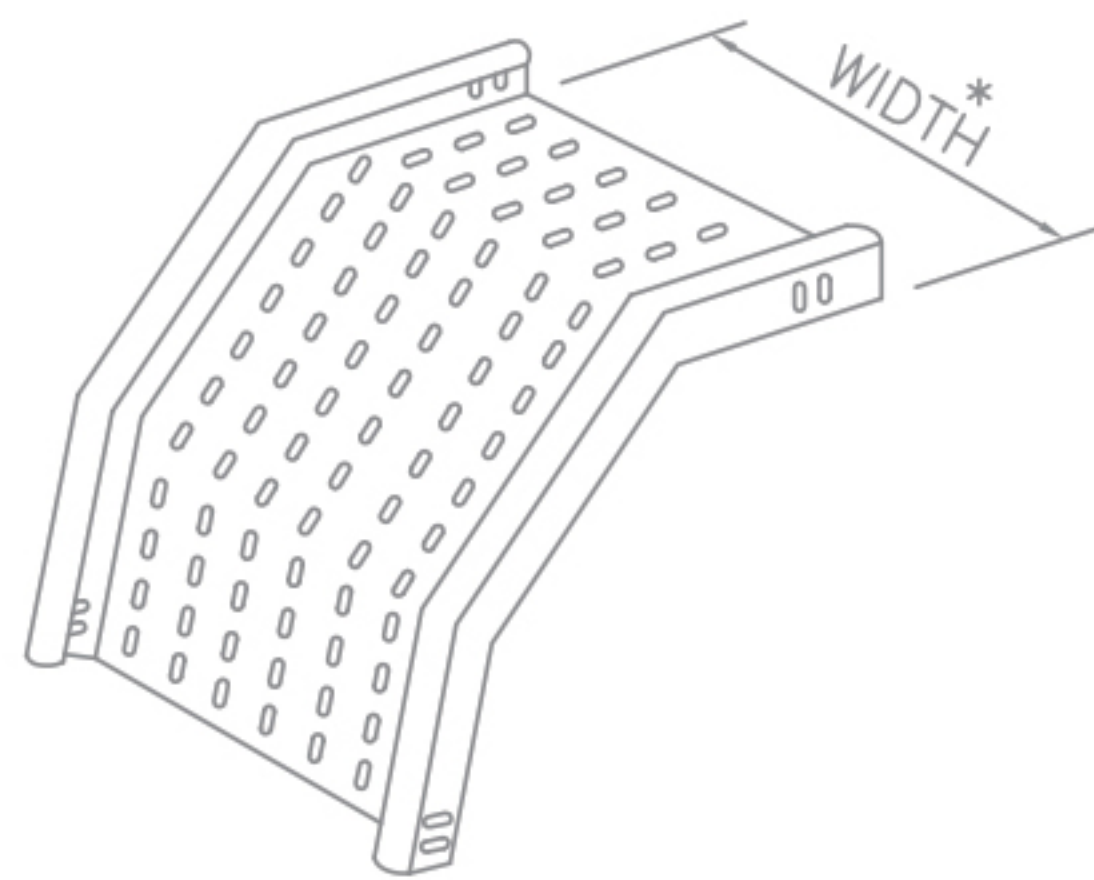

PERFORATED TYPE

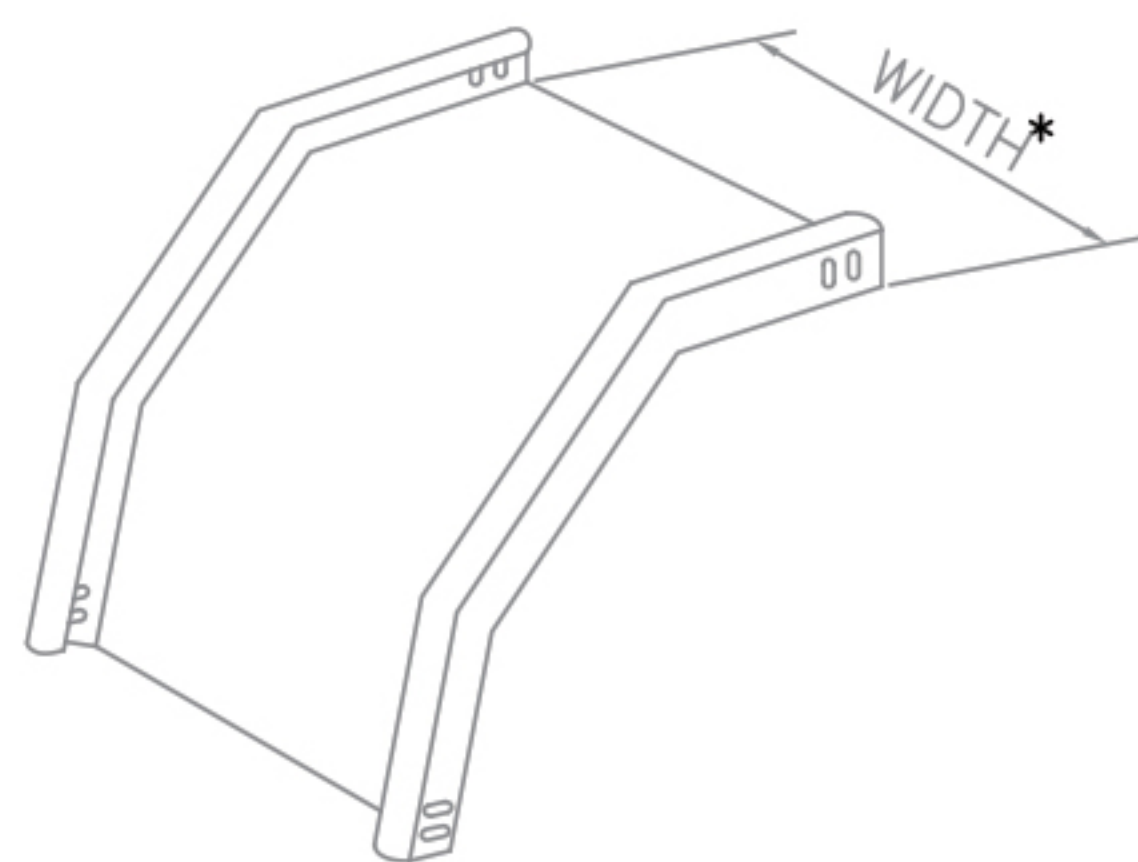

SOLID BOTTOM TYPE

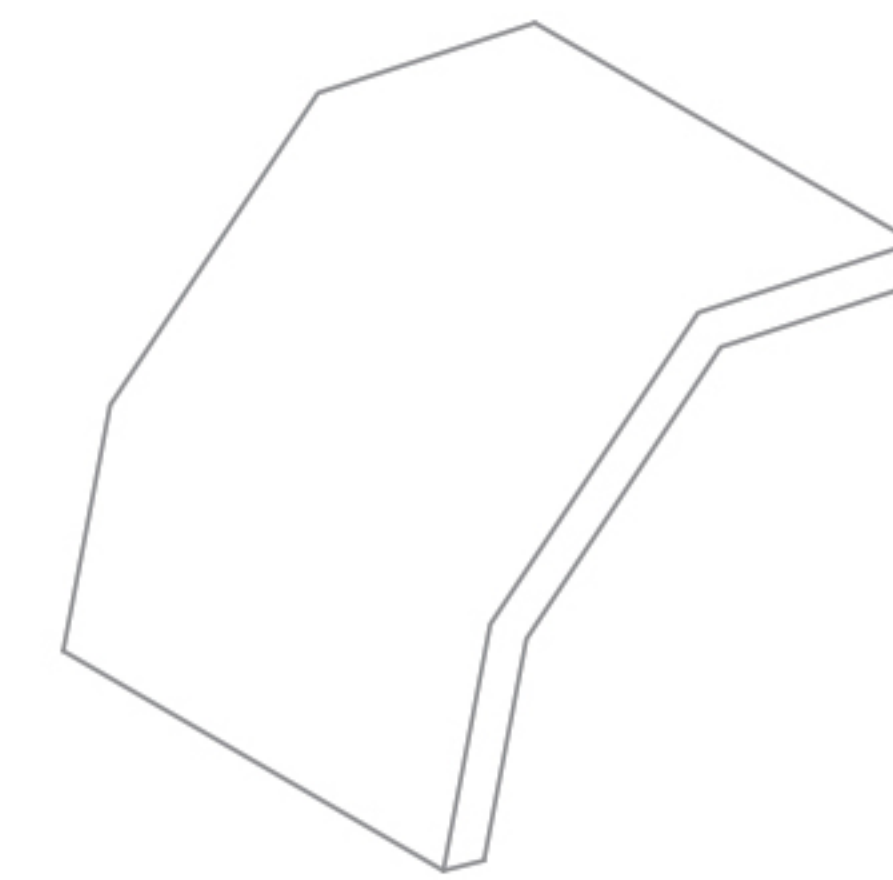
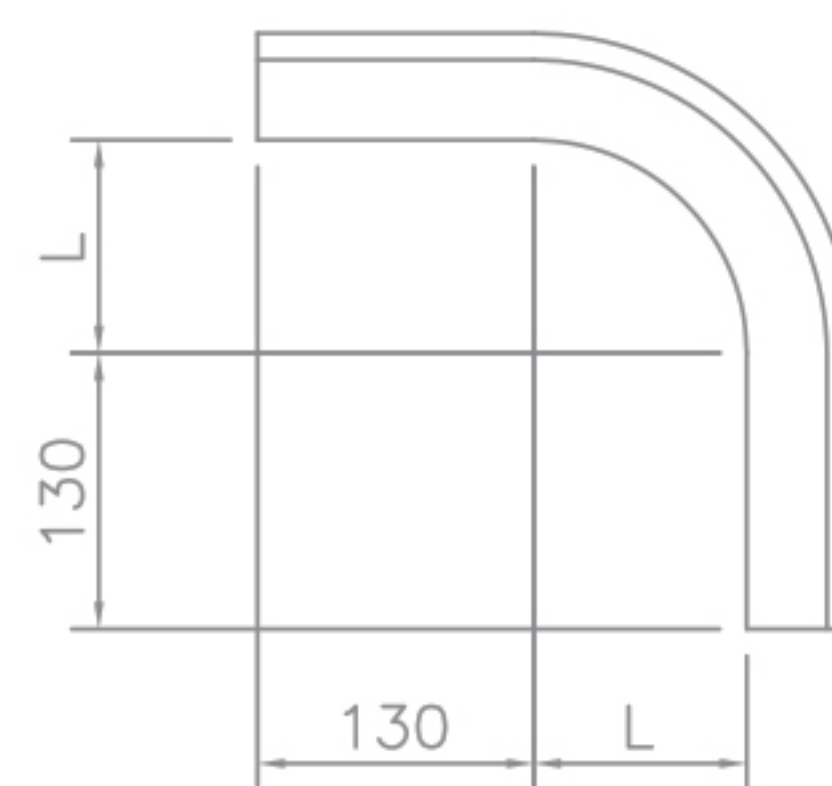

COVER

(Unit : mm)

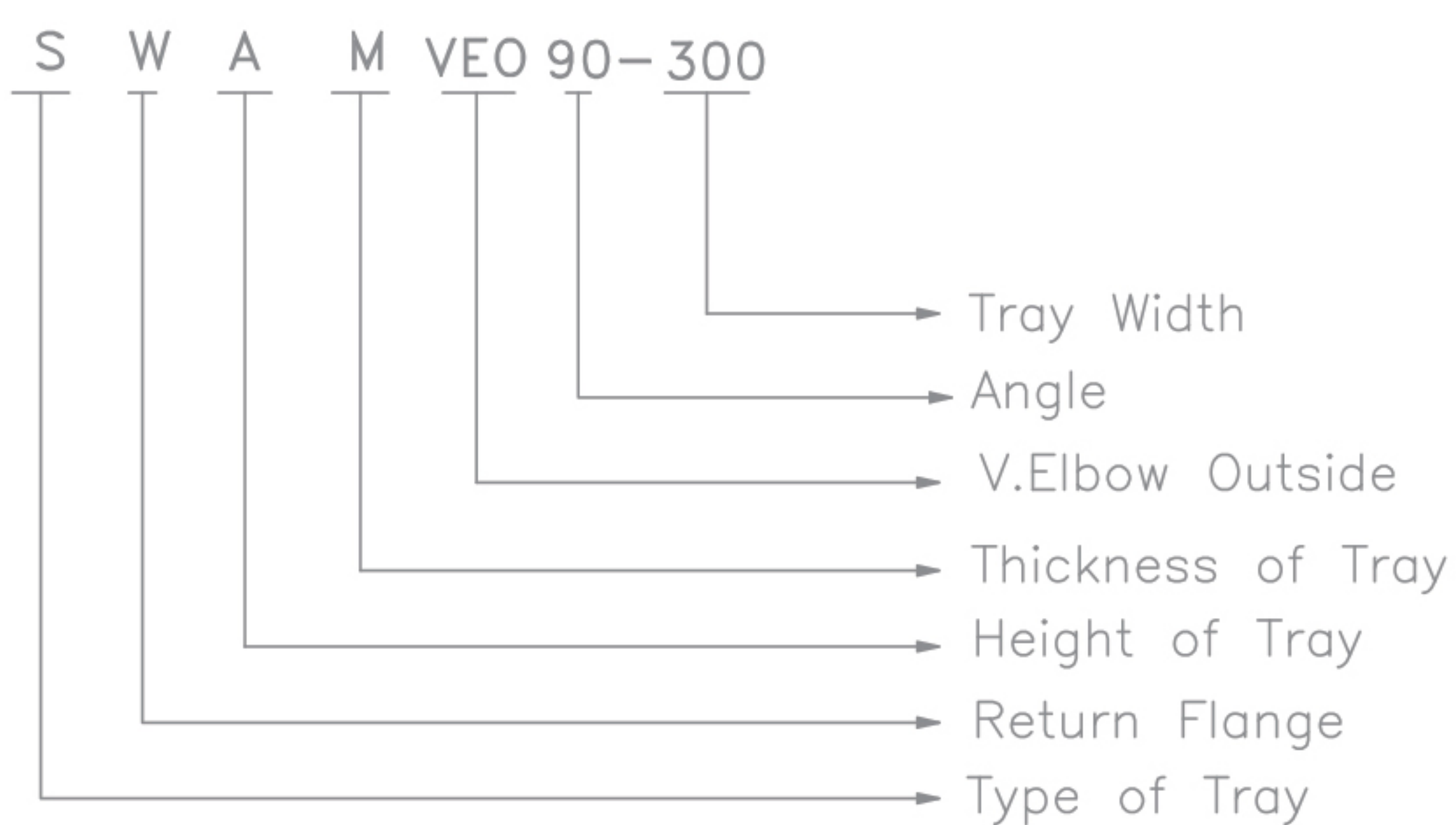

Cat.No.	Tray Width	L	Cover Width	Section
SWALVEI90 - 50	50	170	60	 TRAY
SWALVEI90 - 75	75	170	85	
SWALVEI90 - 100	100	170	110	
SWALVEI90 - 150	150	170	160	
SWALVEI90 - 200	200	170	210	
SWALVEI90 - 250	250	170	260	 TRAY
SWALVEI90 - 300	300	170	310	
SWALVEI90 - 350	350	170	360	
SWALVEI90 - 400	400	170	410	 COVER
SWALVEI90 - 500	500	170	510	
SWALVEI90 - 600	600	170	610	
SWALVEI90 - 750	750	170	760	
SWALVEI90 - 900	900	170	910	

* For Perforated / Solid Cable Trays, the cover width is 5mm more than the width of the tray.
All Dimensions are in mm



CABLE TRAY - PERFORATED / SOLID TYPE FITTINGS & COVERS

900 HORIZONTAL ELBOW

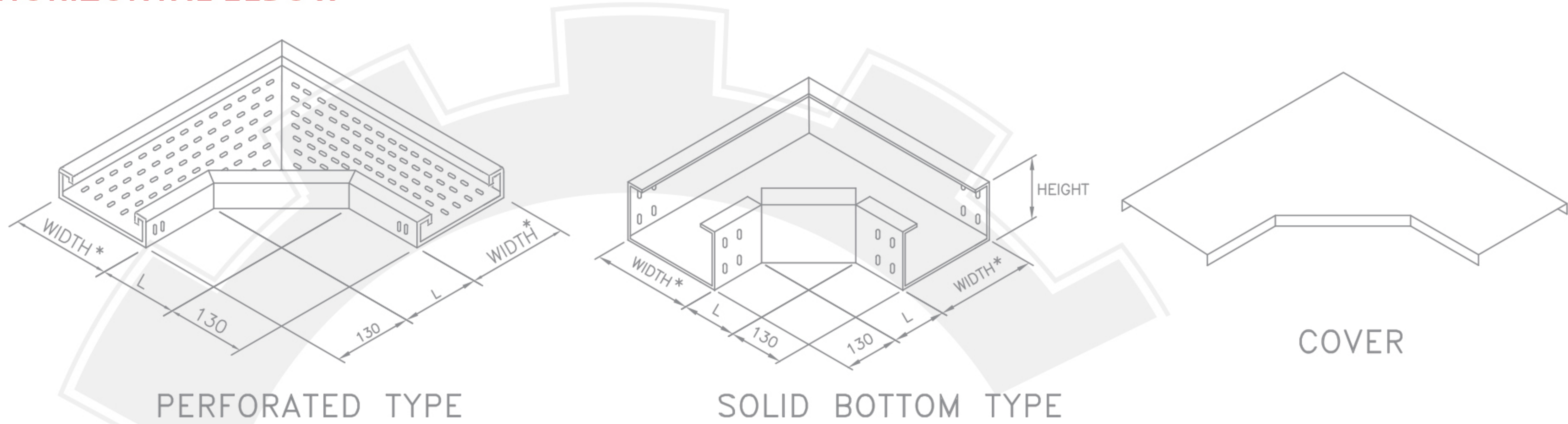

PERFORATED TYPE

SOLID BOTTOM TYPE

COVER

(Unit : mm)

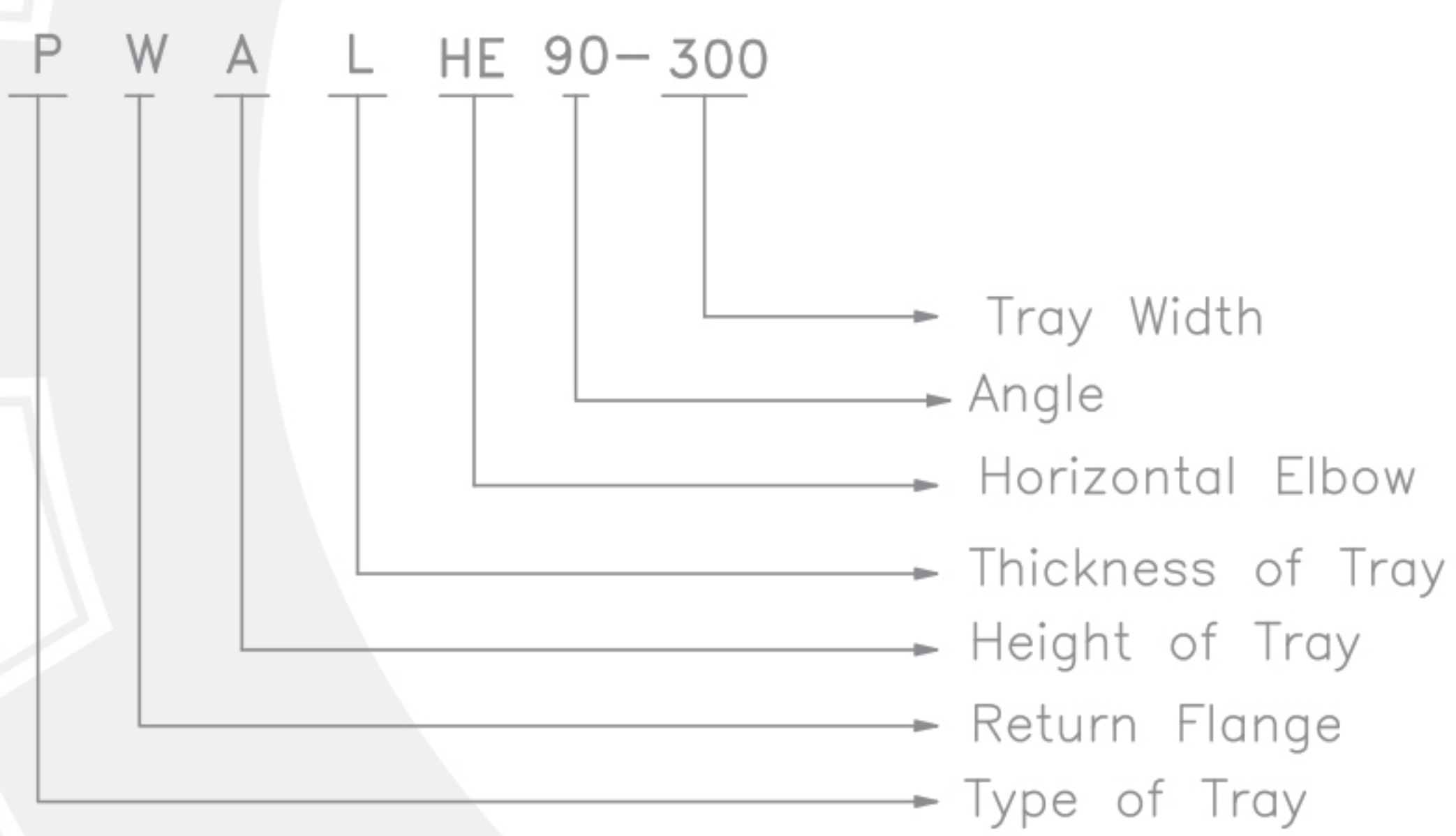

Cat.No.	Tray Width	L	Cover Width	Section
PWALHE90 - 50	50	170	60	 TRAY
PWALHE90 - 100	100	170	110	
PWALHE90 - 150	150	170	160	
PWALHE90 - 200	200	170	210	
PWALHE90 - 250	250	170	260	
PWALHE90 - 300	300	170	310	 TRAY
PWALHE90 - 350	350	170	360	
PWALHE90 - 400	400	170	410	
PWALHE90 - 500	500	170	510	 COVER
PWALHE90 - 600	600	170	610	
PWALHE90 - 750	750	170	760	
PWALHE90 - 900	900	170	910	

STRAIGHT REDUCER

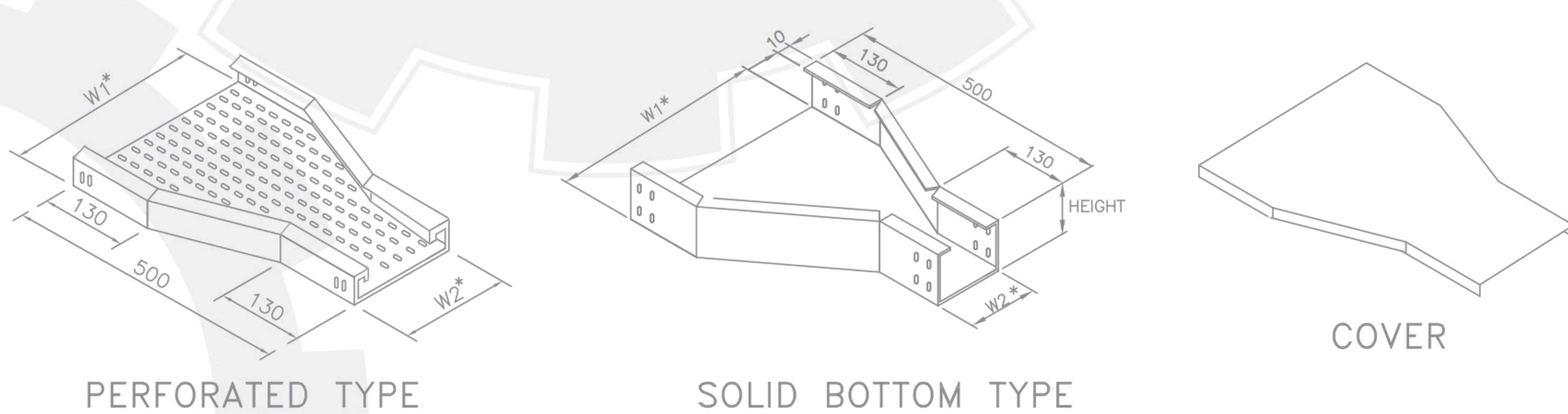

PERFORATED TYPE

SOLID BOTTOM TYPE

COVER

(Unit : mm)

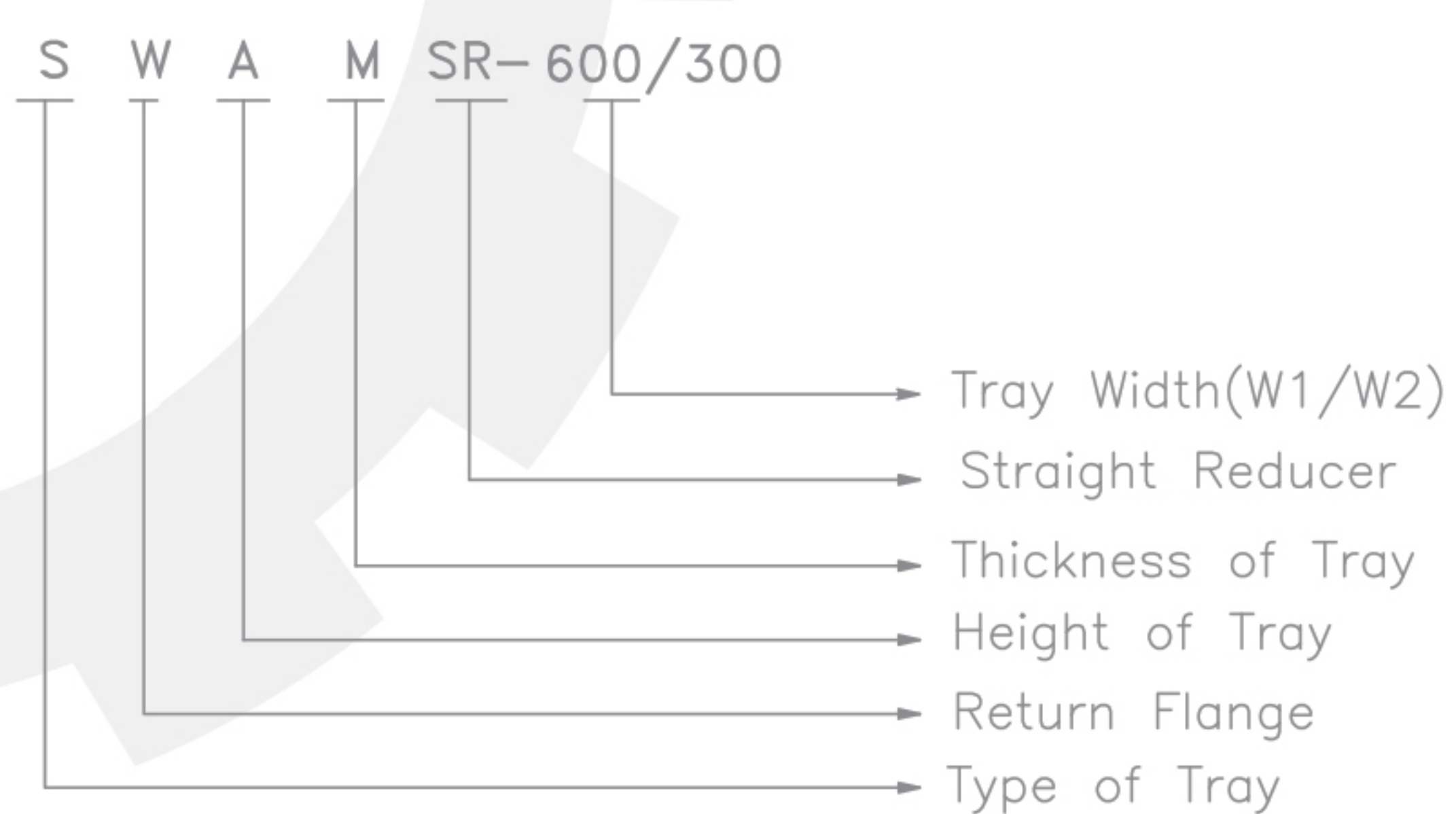

Cat.No.	Tray Width		Cover Width		Section
	W1	W2	WC1	WC2	
SWAL-SR-900/600	900	600	910	610	 TRAY
SWAL-SR-900/400	900	400	910	410	
SWAL-SR-900/200	900	200	910	210	
SWAL-SR-750/500	750	500	760	510	 TRAY
SWAL-SR-750/300	750	300	760	310	
SWAL-SR-750/200	750	200	760	210	
SWAL-SR-600/400	600	400	610	410	 TRAY
SWAL-SR-600/250	600	250	610	260	
SWAL-SR-600/200	600	200	610	210	
SWALSR-300/250	300	250	310	260	 COVER
SWAL-SR-300/200	300	200	310	210	

All Dimensions are in mm



CABLE TRAY - PERFORATED / SOLID TYPE FITTINGS & COVERS

LEFT HAND REDUCER

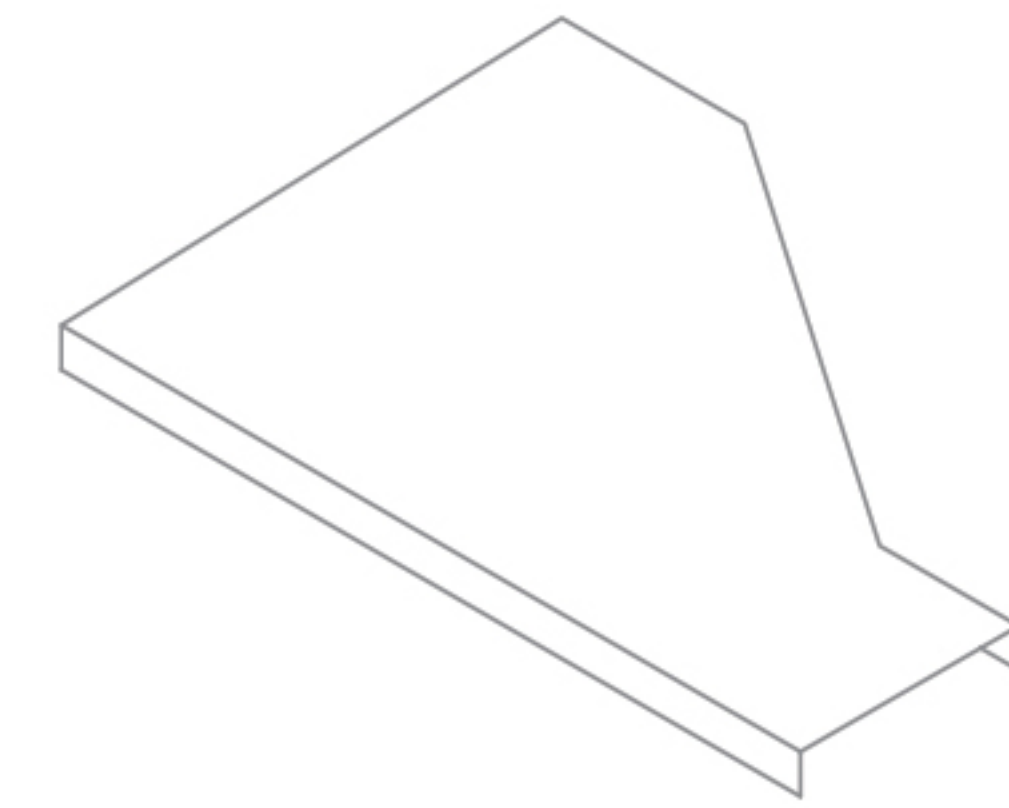
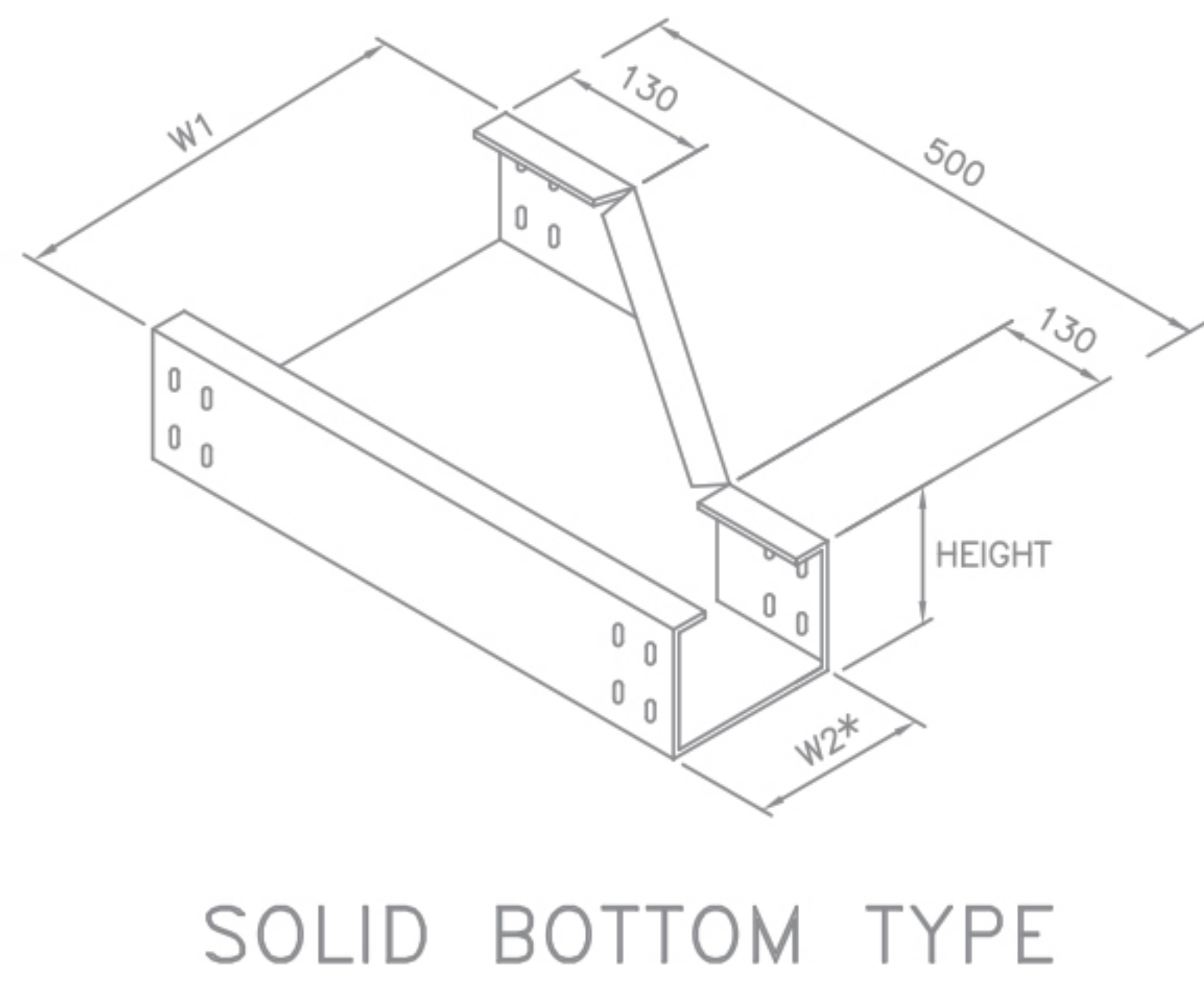
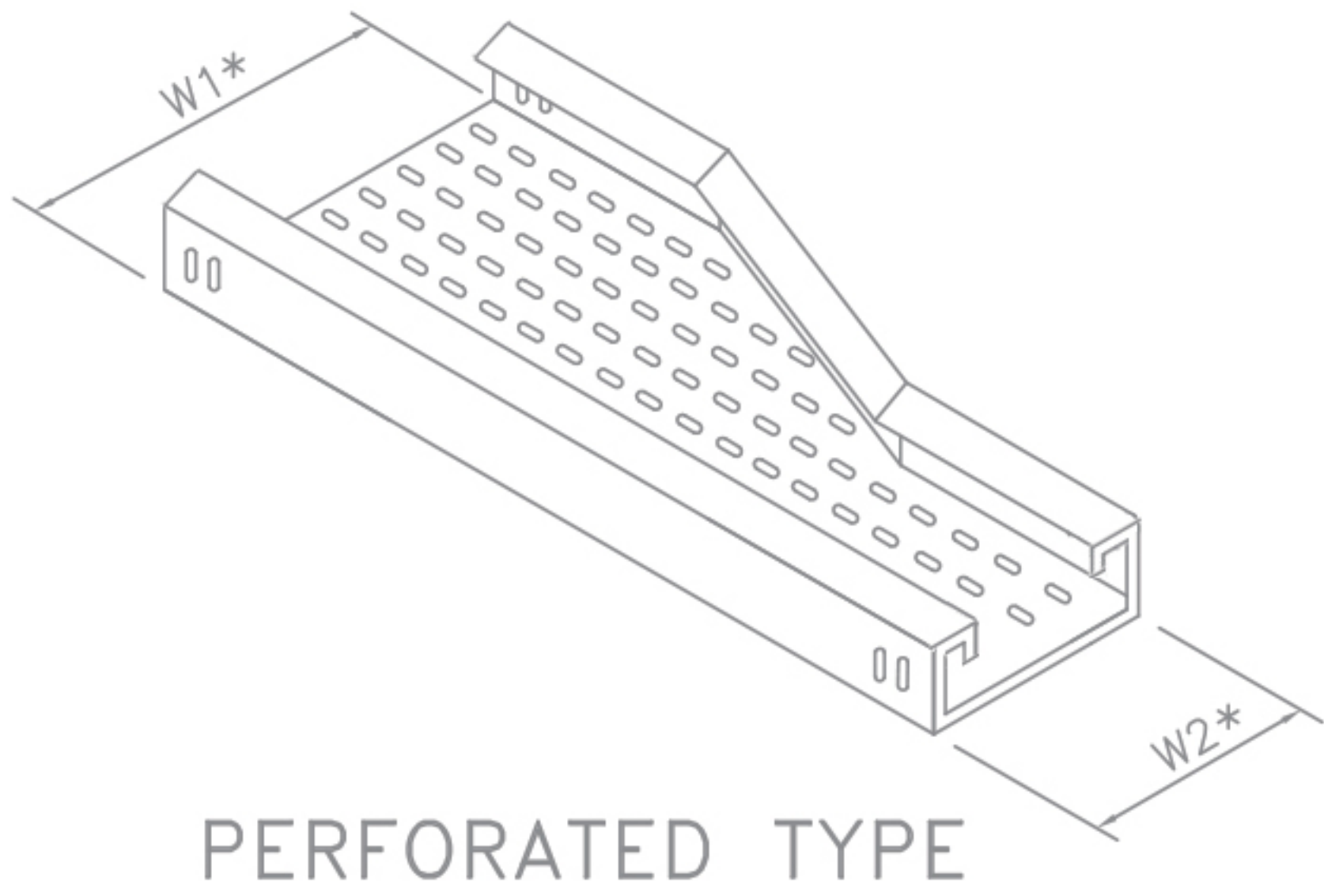

COVER

(Unit : mm)

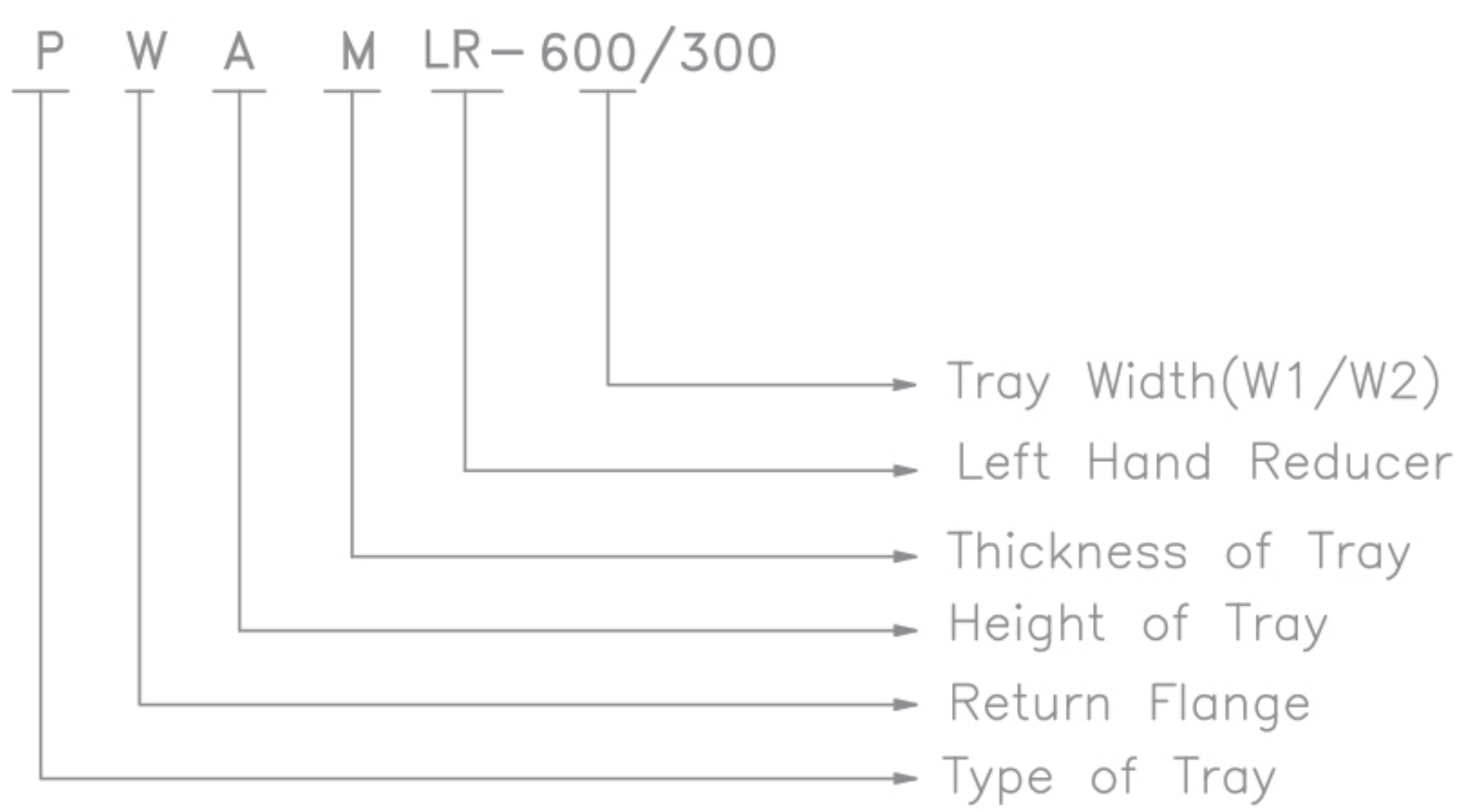

Cat.No.	Tray Width		Cover Width		Section
	W1	W2	WC1	WC2	
SWAL-LR-900/600	900	600	910	610	TRAY
SWAL-LR-900/400	900	400	910	410	
SWAL-SR-900/200	900	200	910	210	
SWAL-LR-750/500	750	500	760	510	TRAY
SWAL-LR-750/300	750	300	760	310	
SWAL-LR-750/200	750	200	760	210	
SWAL-LR-600/400	600	400	610	410	TRAY
SWAL-LR-600/250	600	250	610	260	
SWAL-LR-600/200	600	200	610	210	
SWAL-LR-300/250	300	250	310	260	COVER
SWAL-SR-300/200	300	200	310	210	

RIGHT HAND REDUCER

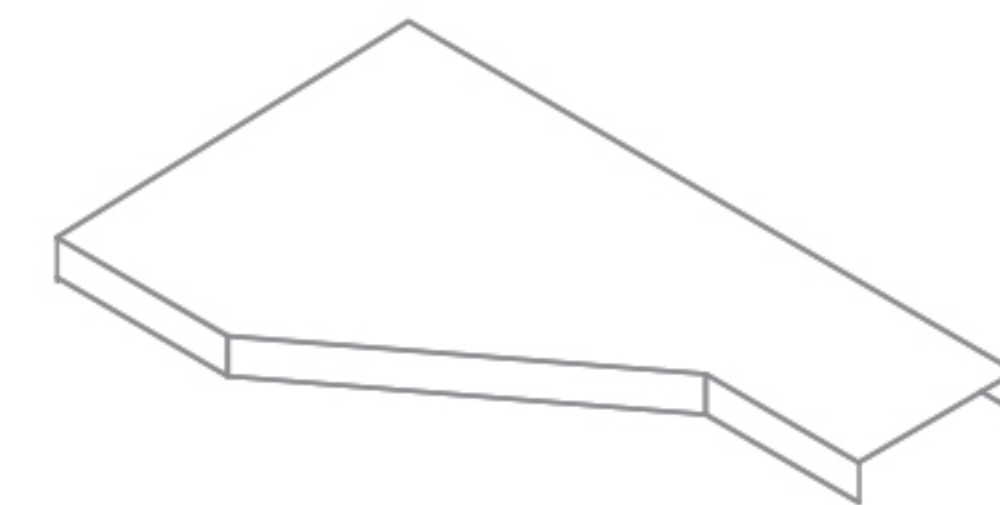
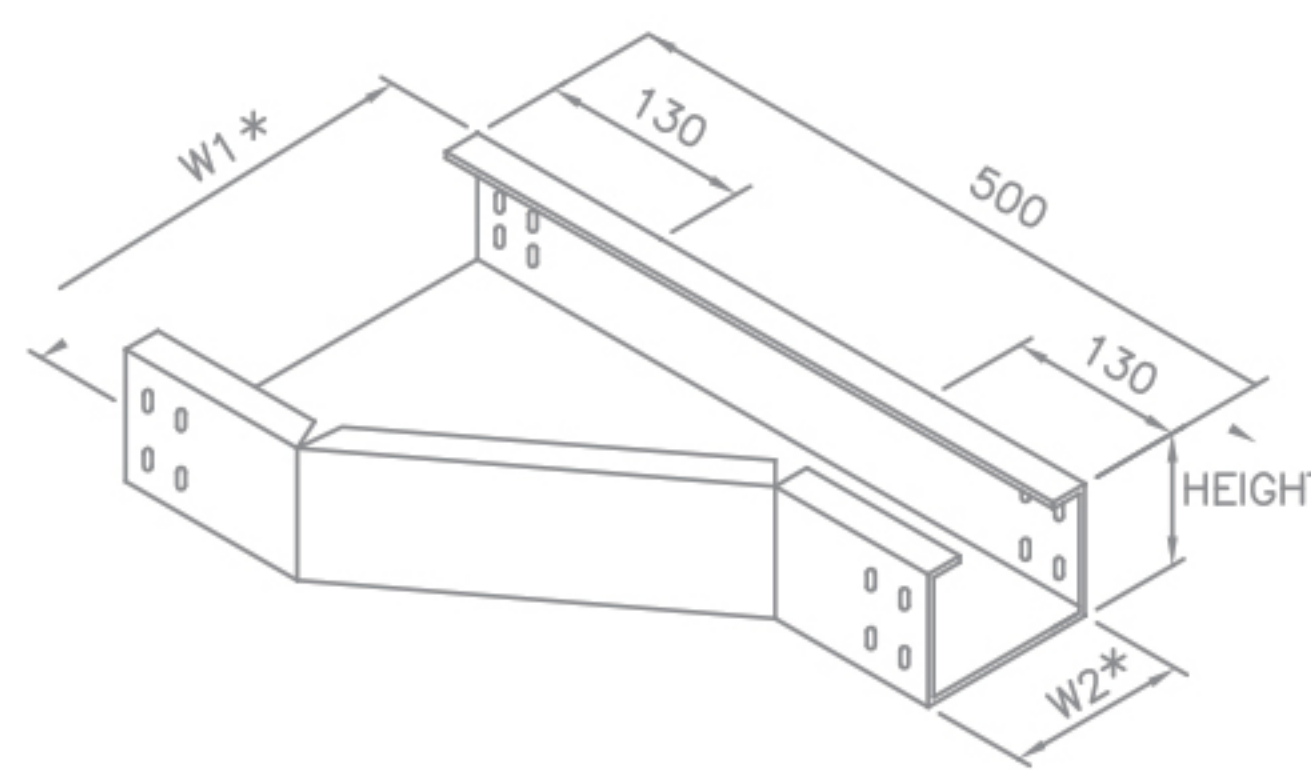
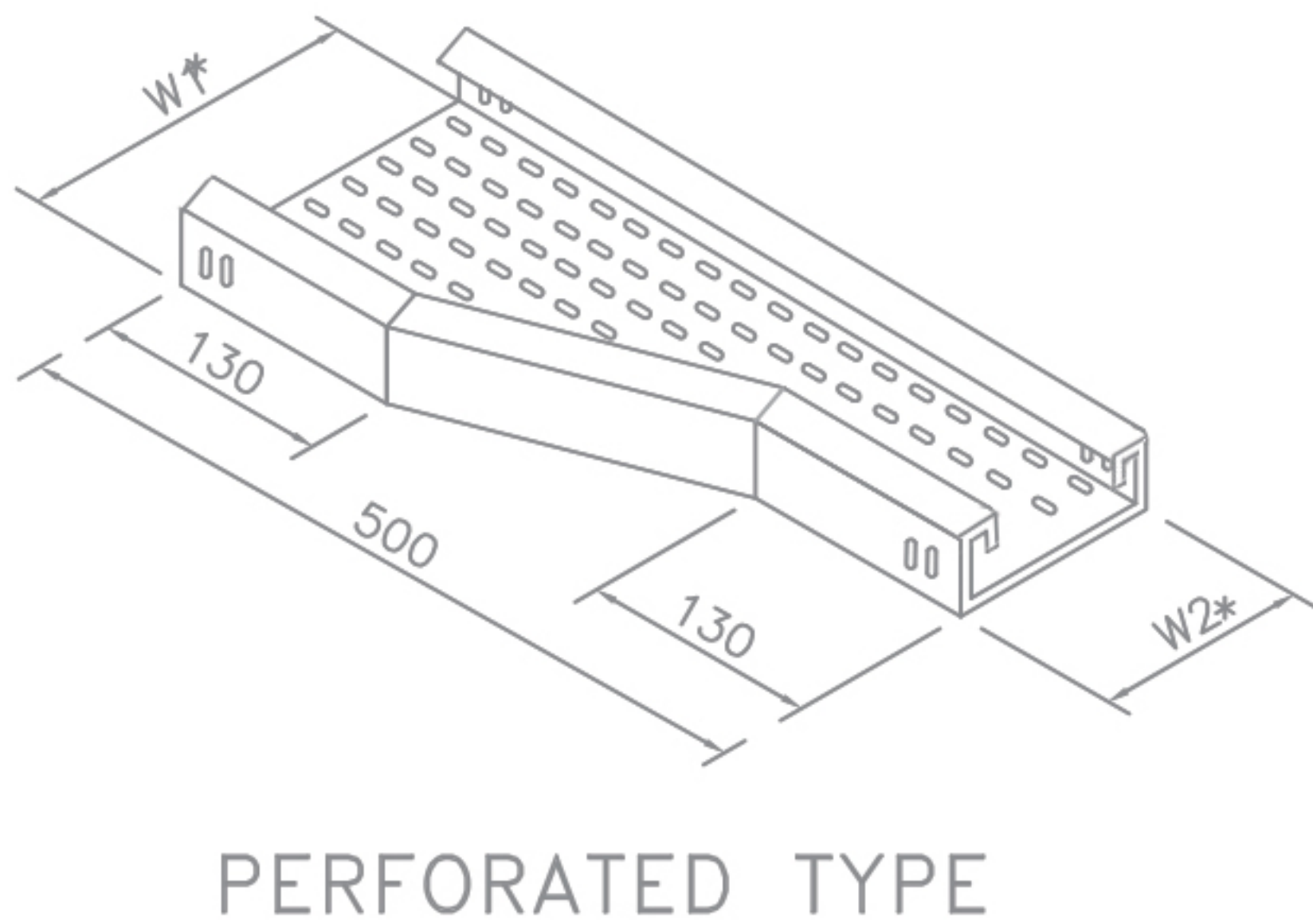

COVER

(Unit : mm)

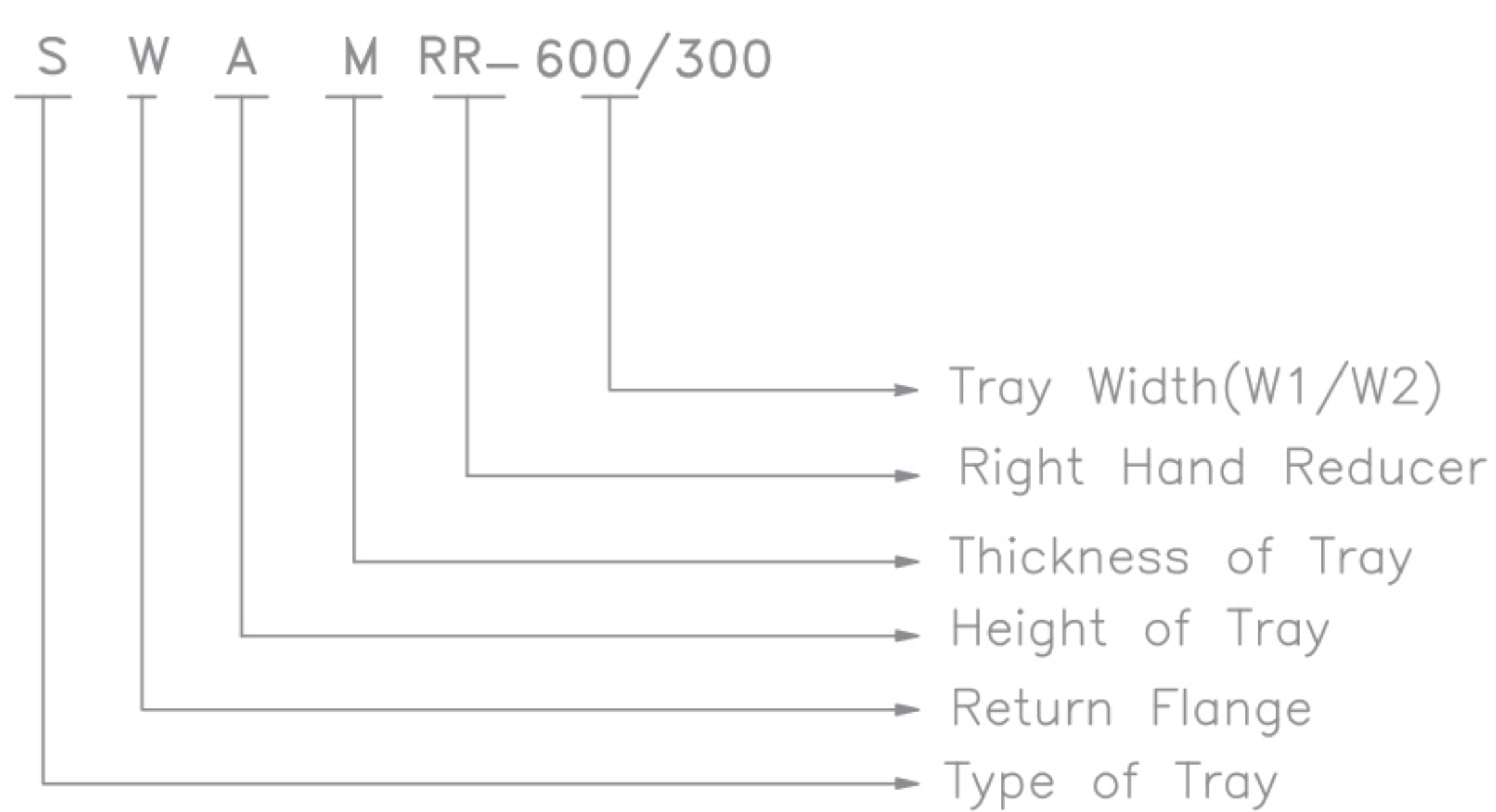

Cat.No.	Tray Width		Cover Width		Section
	W1	W2	WC1	WC2	
SWAL-RR-900/600	900	600	910	610	TRAY
SWAL-RR-900/400	900	400	910	410	
SWAL-RR-900/200	900	200	910	210	
SWAL-RR-750/500	750	500	760	510	TRAY
SWAL-RR-750/300	750	300	760	310	
SWAL-RR-750/200	750	200	760	210	
SWAL-RR-600/400	600	400	610	410	TRAY
SWAL-RR-600/250	600	250	610	260	
SWAL-RR-600/200	600	200	610	210	
SWAL-RR-300/250	300	250	310	260	COVER
SWAL-RR-300/200	300	200	310	210	

* For Perforated / Solid Cable Trays, the cover width is 5mm more than the width of the tray.
All Dimensions are in mm



CABLE TRAY - PERFORATED / SOLID TYPE FITTINGS & COVERS

HORIZONTAL TEE

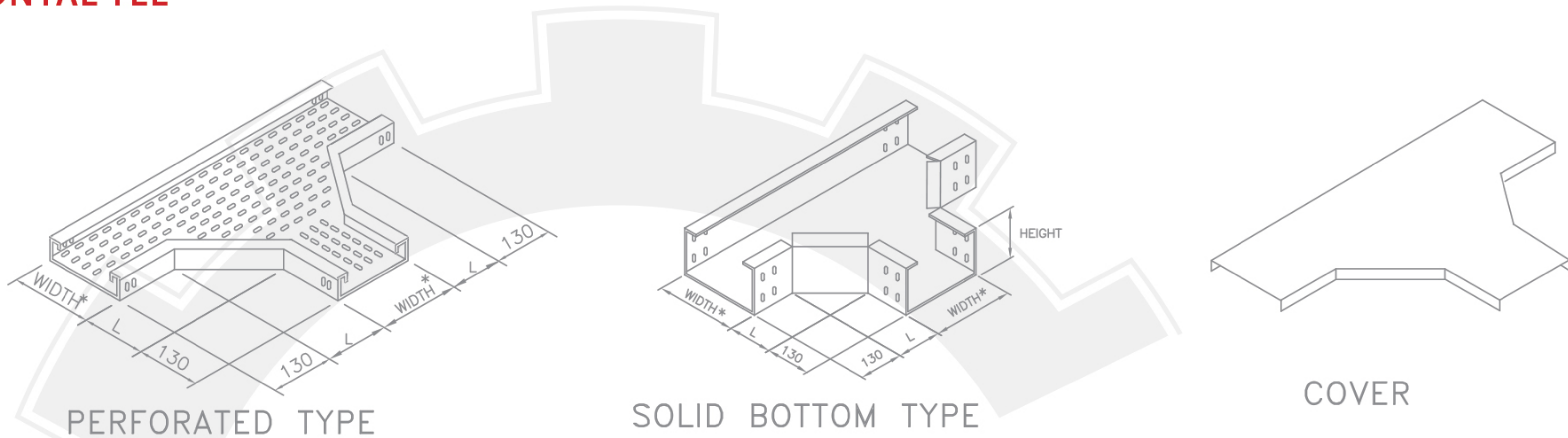

PERFORATED TYPE

SOLID BOTTOM TYPE

COVER

(Unit : mm)

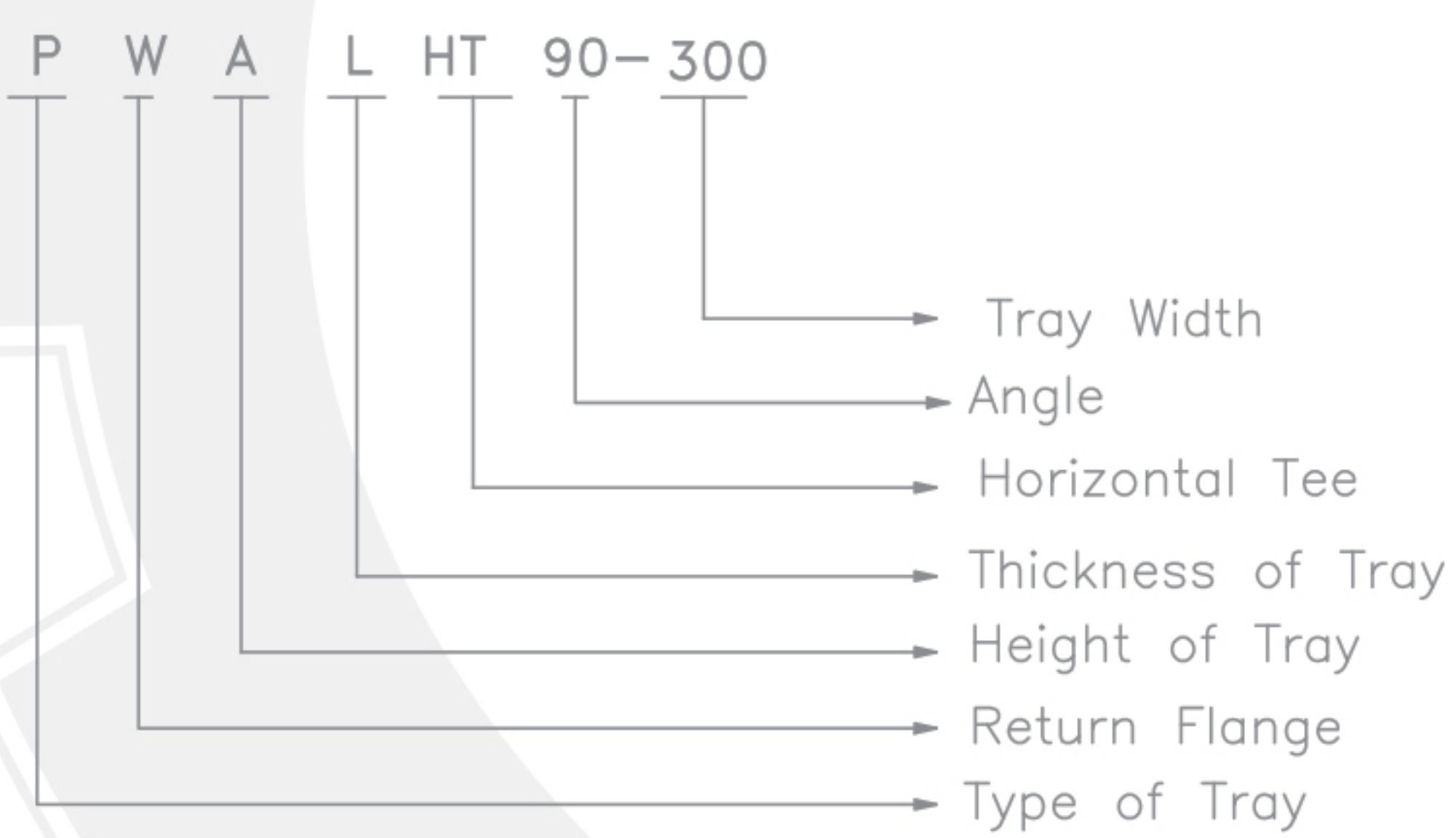

Cat.No.	Tray Width	L	Cover Width	Section
PWALHT90 - 50	50	170	60	 TRAY
PWALHT90 - 75	75	170	85	
PWALHT90 - 100	100	170	110	
PWALHT90 - 150	150	170	160	
PWALHT90 - 200	200	170	210	
PWALHT90 - 250	250	170	260	
PWALHT90 - 300	300	170	310	 TRAY
PWALHT90 - 350	350	170	360	
PWALHT90 - 400	400	170	410	
PWALHT90 - 500	500	170	510	 COVER
PWALHT90 - 600	600	170	610	
PWALHT90 - 750	750	170	760	
PWALHT90 - 900	900	170	910	

HORIZONTAL CROSS

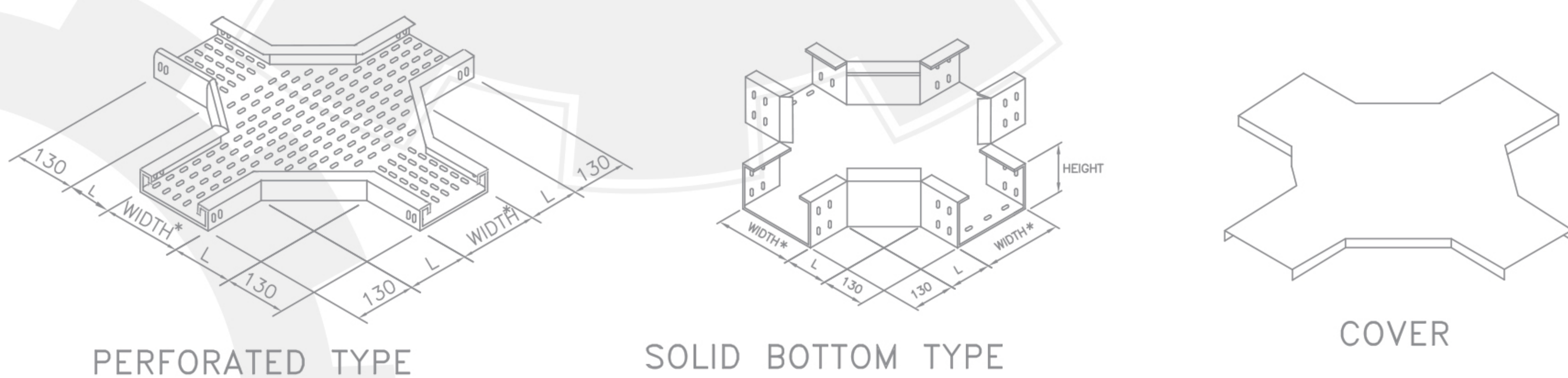



PERFORATED TYPE

SOLID BOTTOM TYPE

COVER

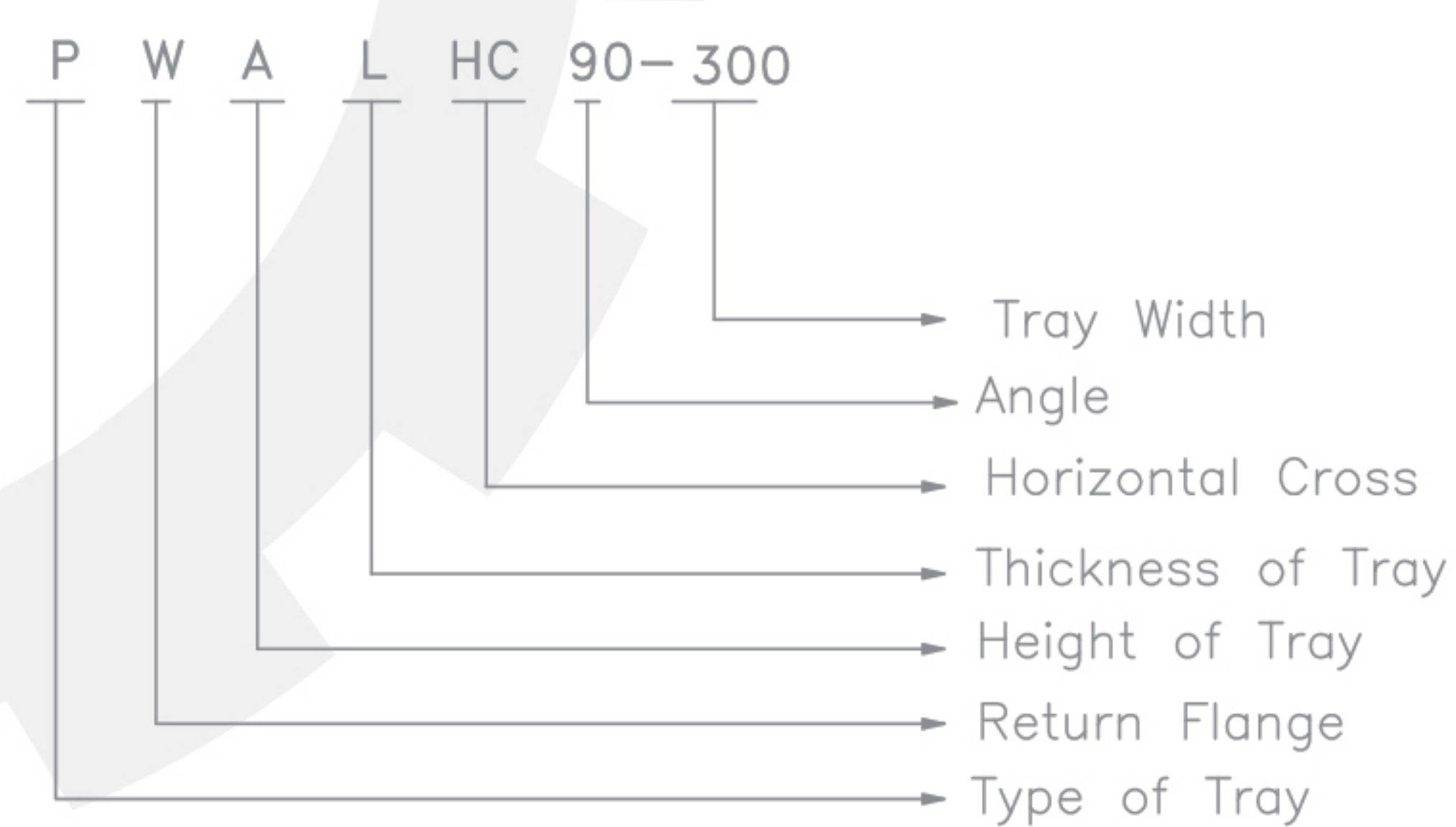
(Unit : mm)



Cat.No.	Tray Width	L	Cover Width	Section
PWALHC90 - 50	50	170	60	 TRAY
PWALHC90 - 75	75	170	85	
PWALHC90 - 100	100	170	110	
PWALHC90 - 150	150	170	160	
PWALHC90 - 200	200	170	210	
PWALHC90 - 250	250	170	260	
PWALHC90 - 300	300	170	310	 TRAY
PWALHC90 - 350	350	170	360	
PWALHC90 - 400	400	170	410	
PWALHC90 - 500	500	170	510	 COVER
PWALHC90 - 600	600	170	610	
PWALHC90 - 750	750	170	760	
PWALHC90 - 900	900	170	910	

All Dimensions are in mm



CABLE TRAY - PERFORATED / SOLID TYPE ACCESSORIES

COVER

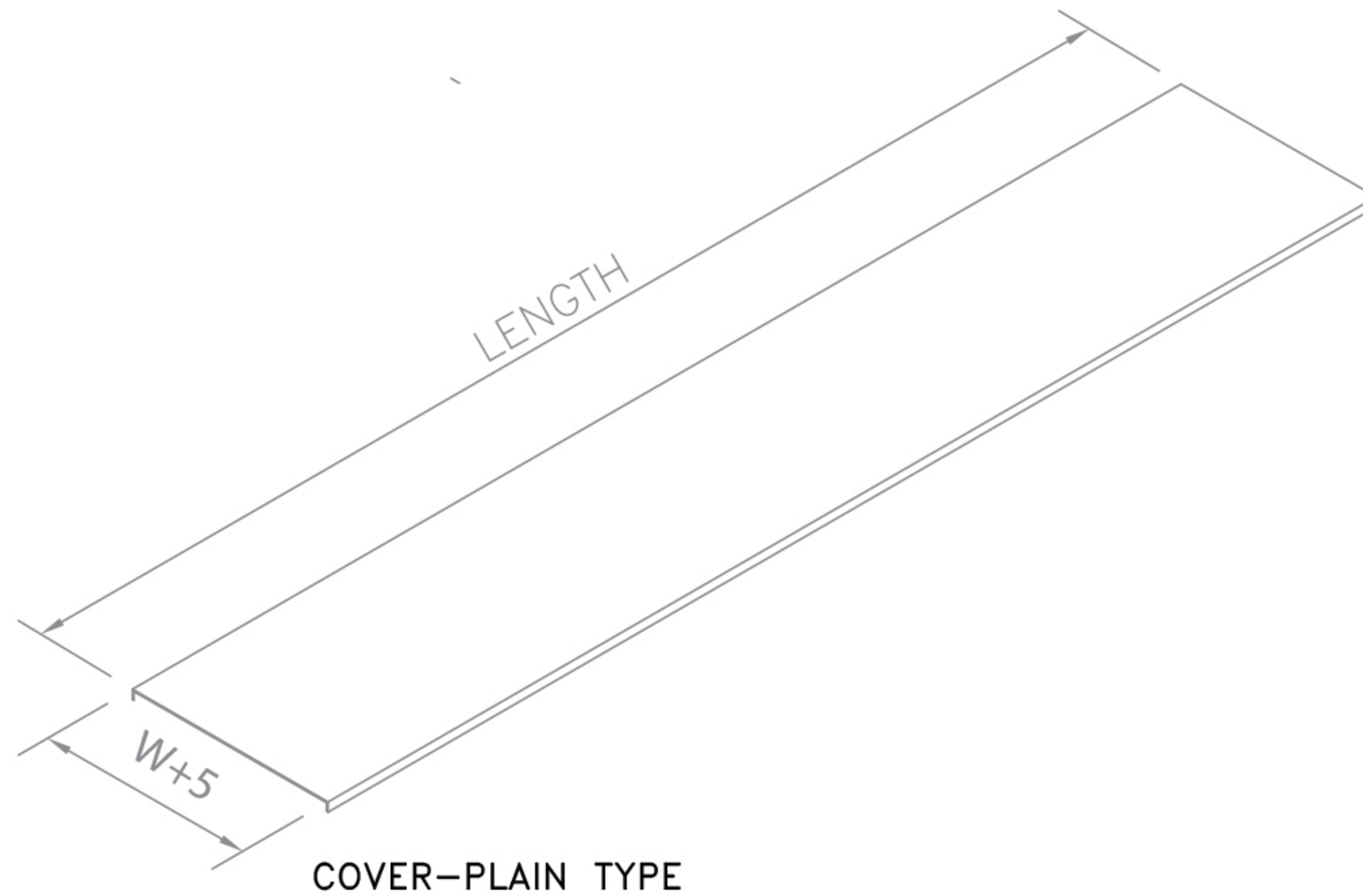

FOR CABLE TRAYS , COVER WIDTH IS $W+10\text{MM}$

MATERIAL : MILD STEEL/STAINLESS STEEL/ALUMINIUM

FINISH : HOT DIP GALVANIZED/PAINTED/POWDERCOATED

HOLD DOWN CLAMP(TYPE-B)

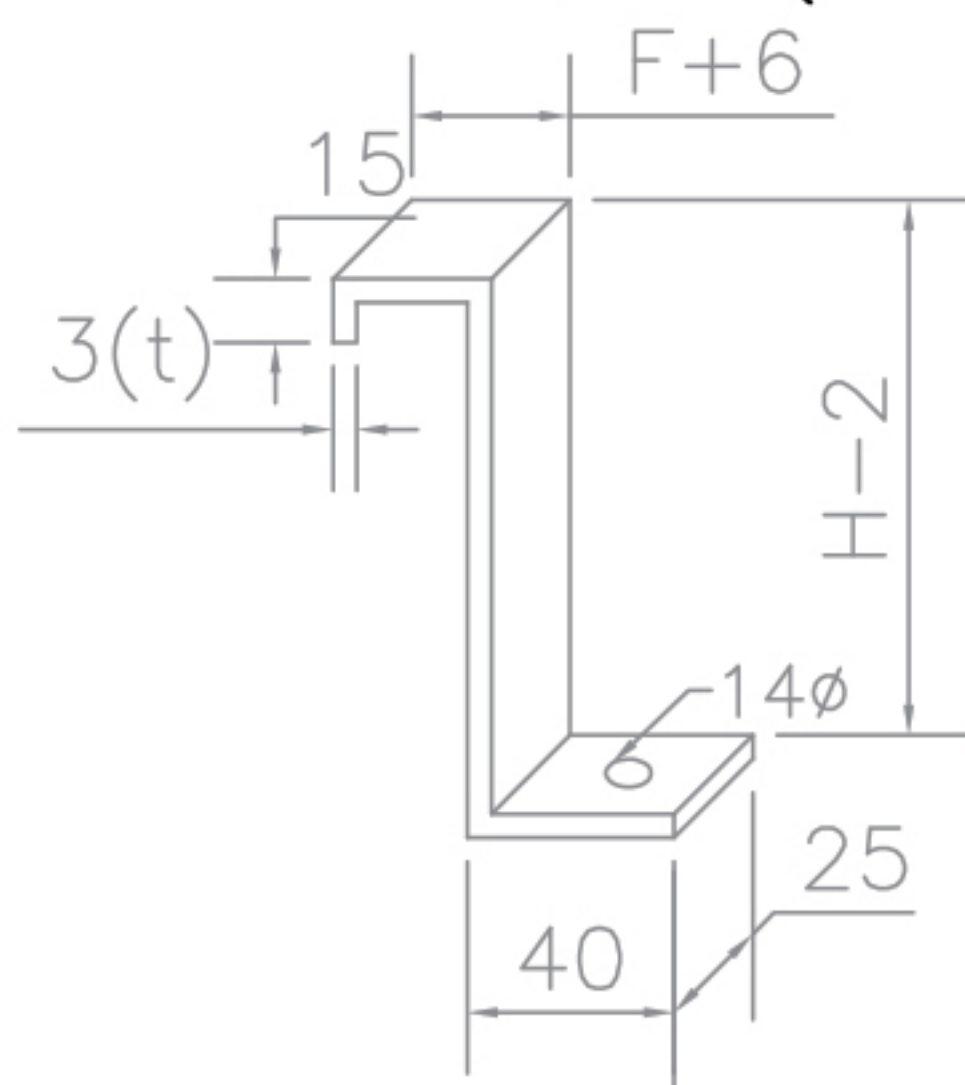

COVER CLAMP- TYPE C

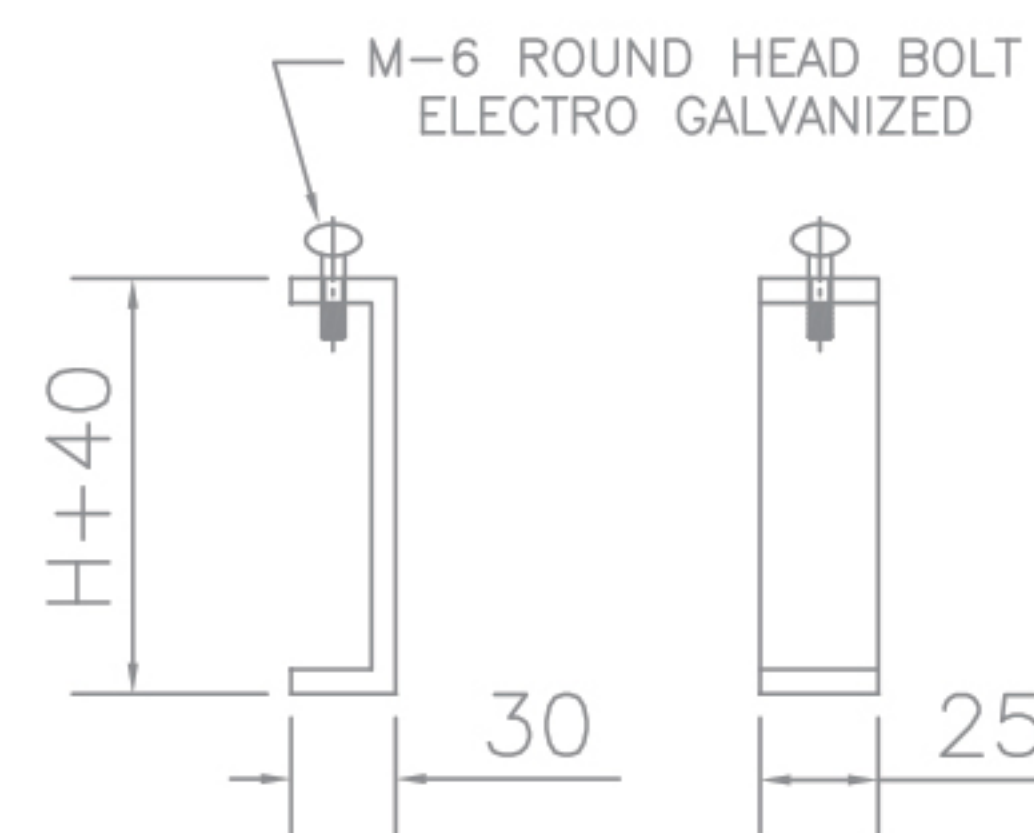

COVER CLAMP- TYPE B

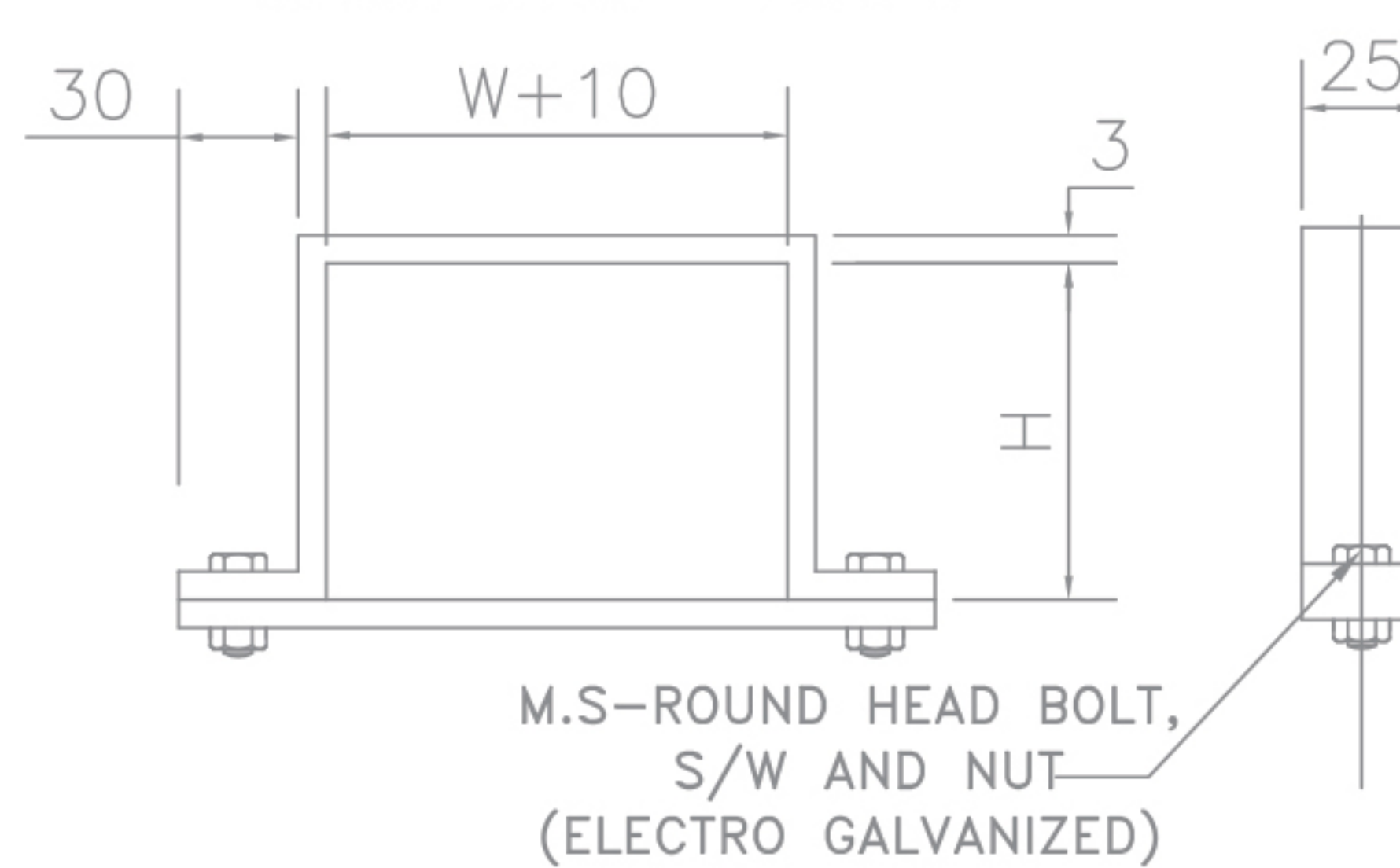

All Dimensions are in mm



CABLE TRAY - PERFORATED / SOLID TYPE

ACCESSORIES

WALL STRAIGHT JOINT

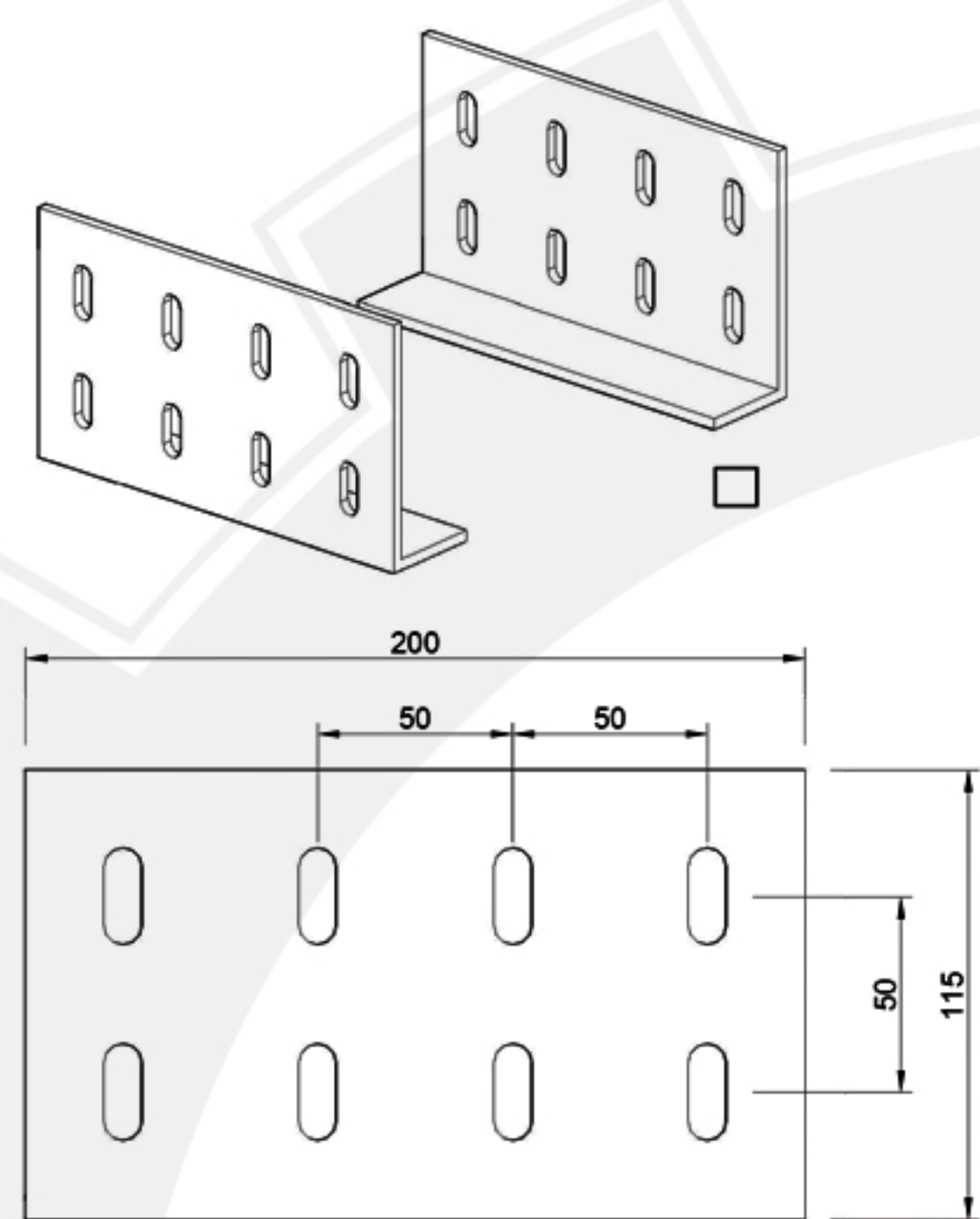

END PLATE

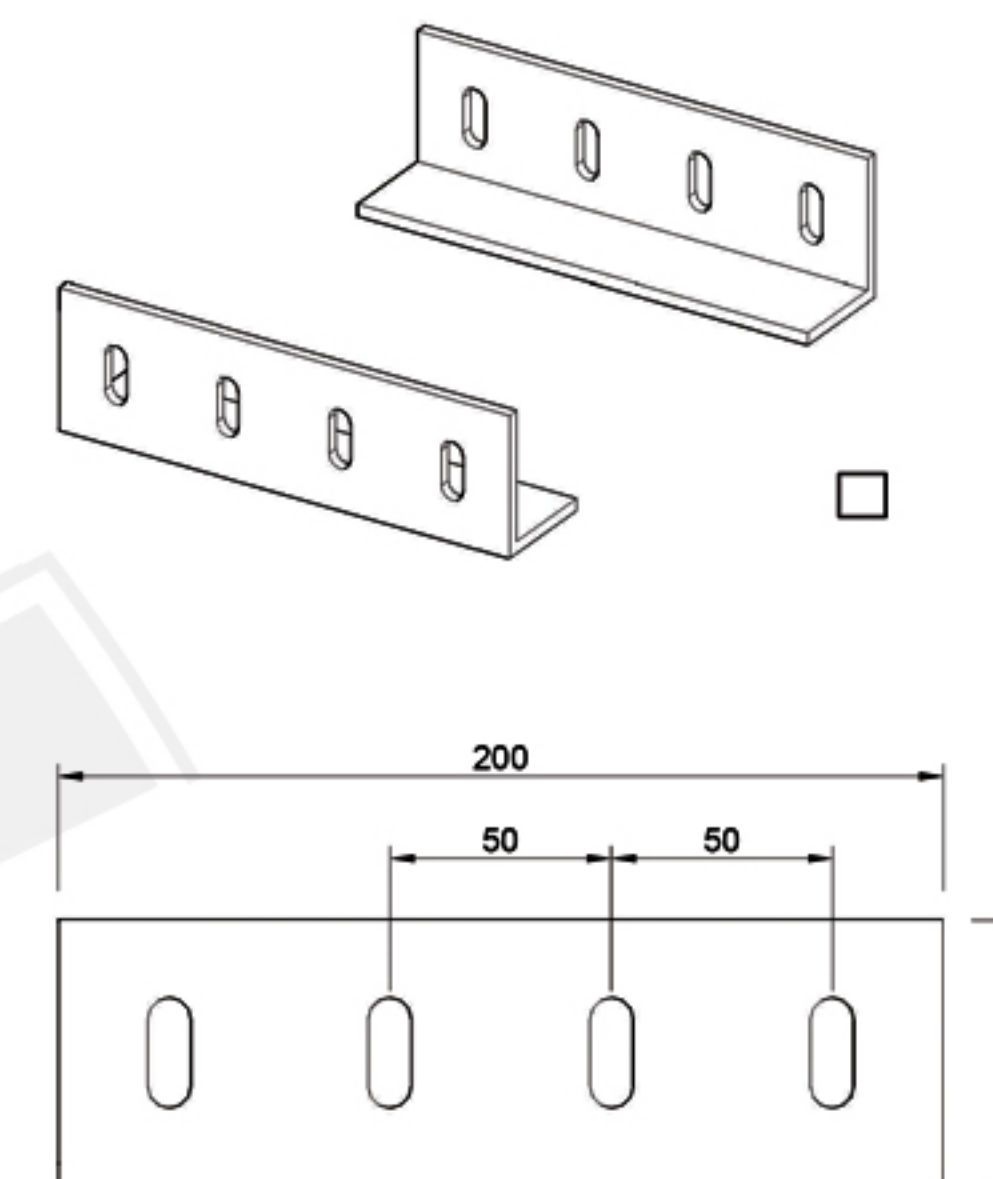
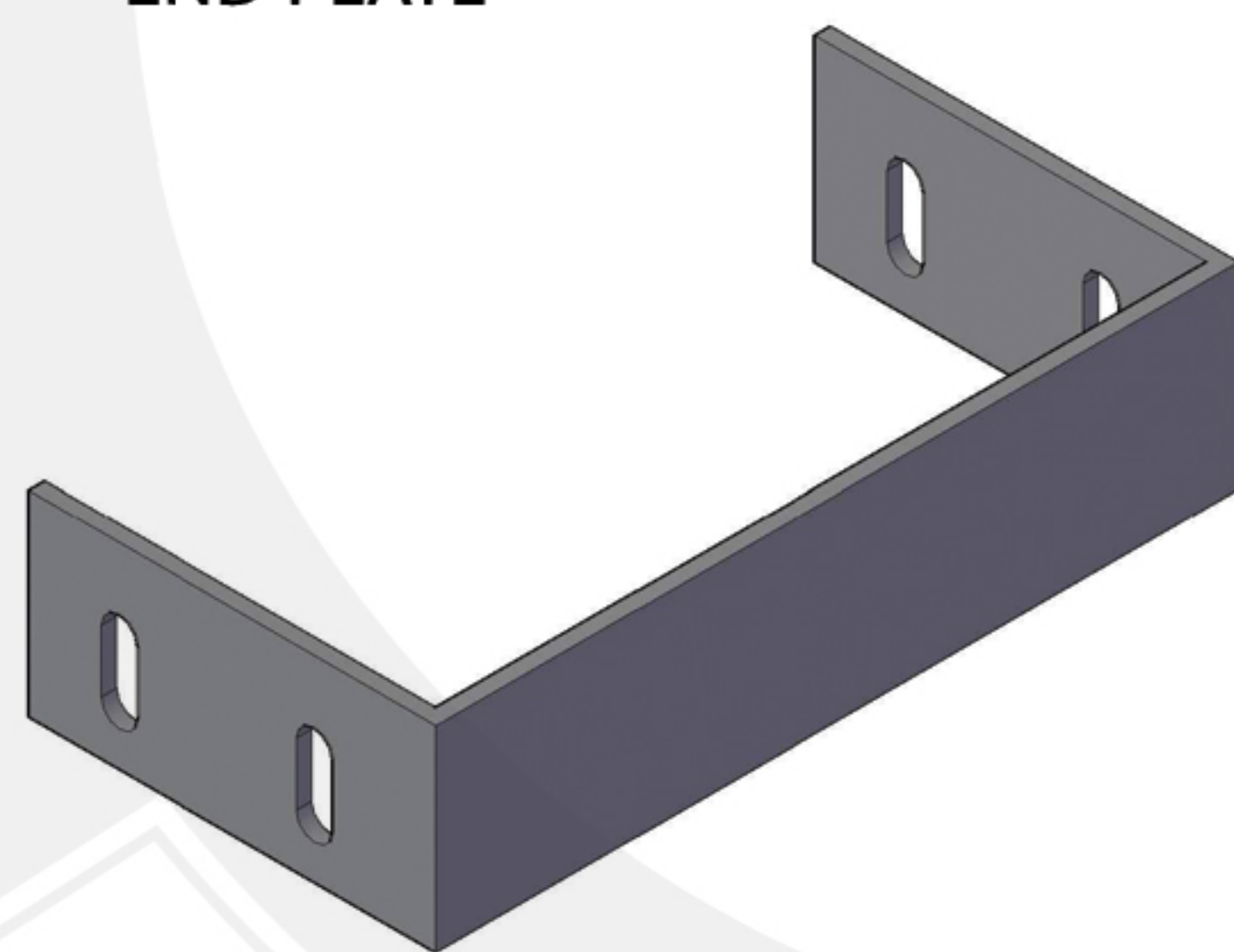

STRAIGHT JOINT

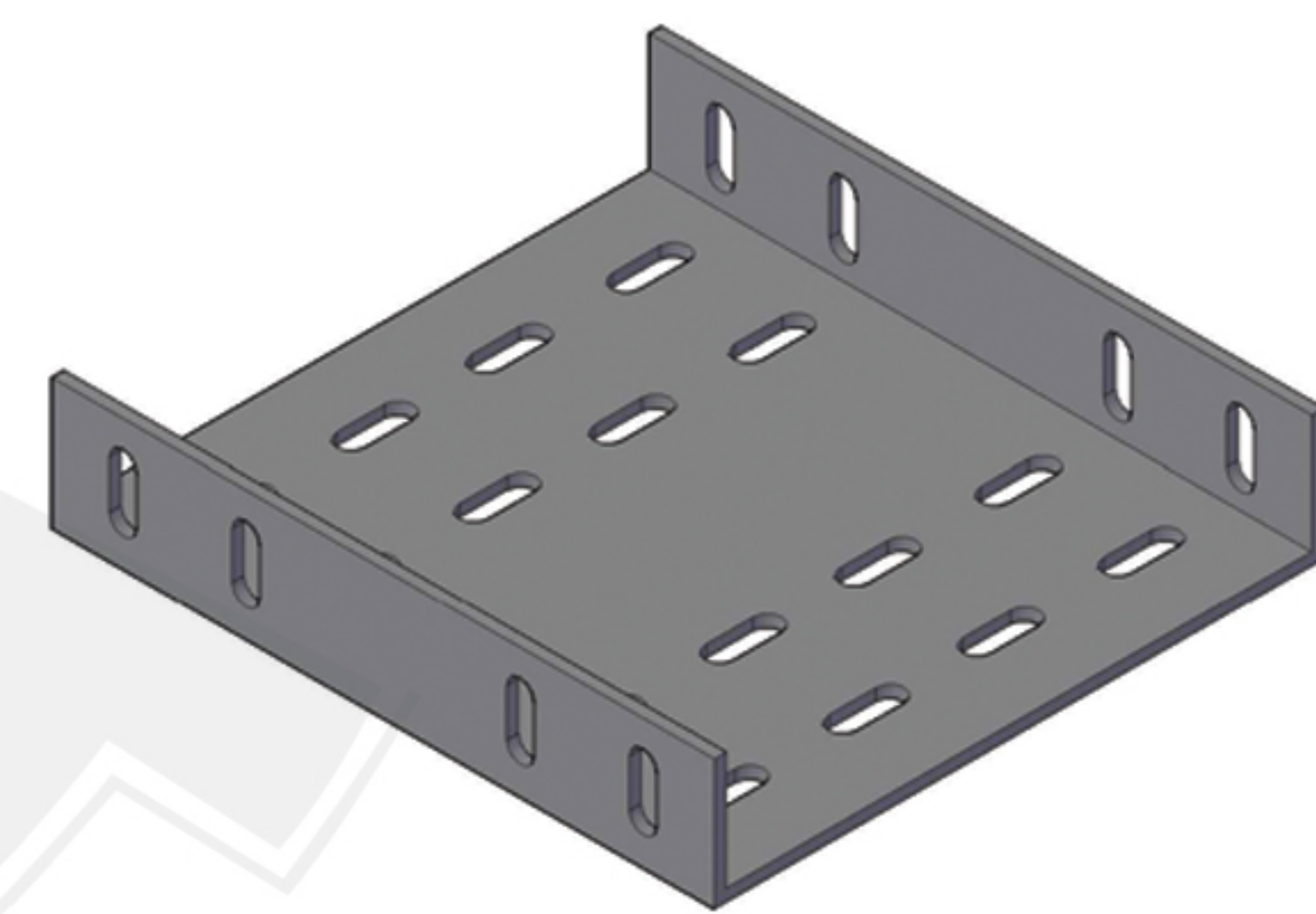

RISER CONNECTOR(RCP)
VERTICAL ADJUSTABLE CONNECTOR

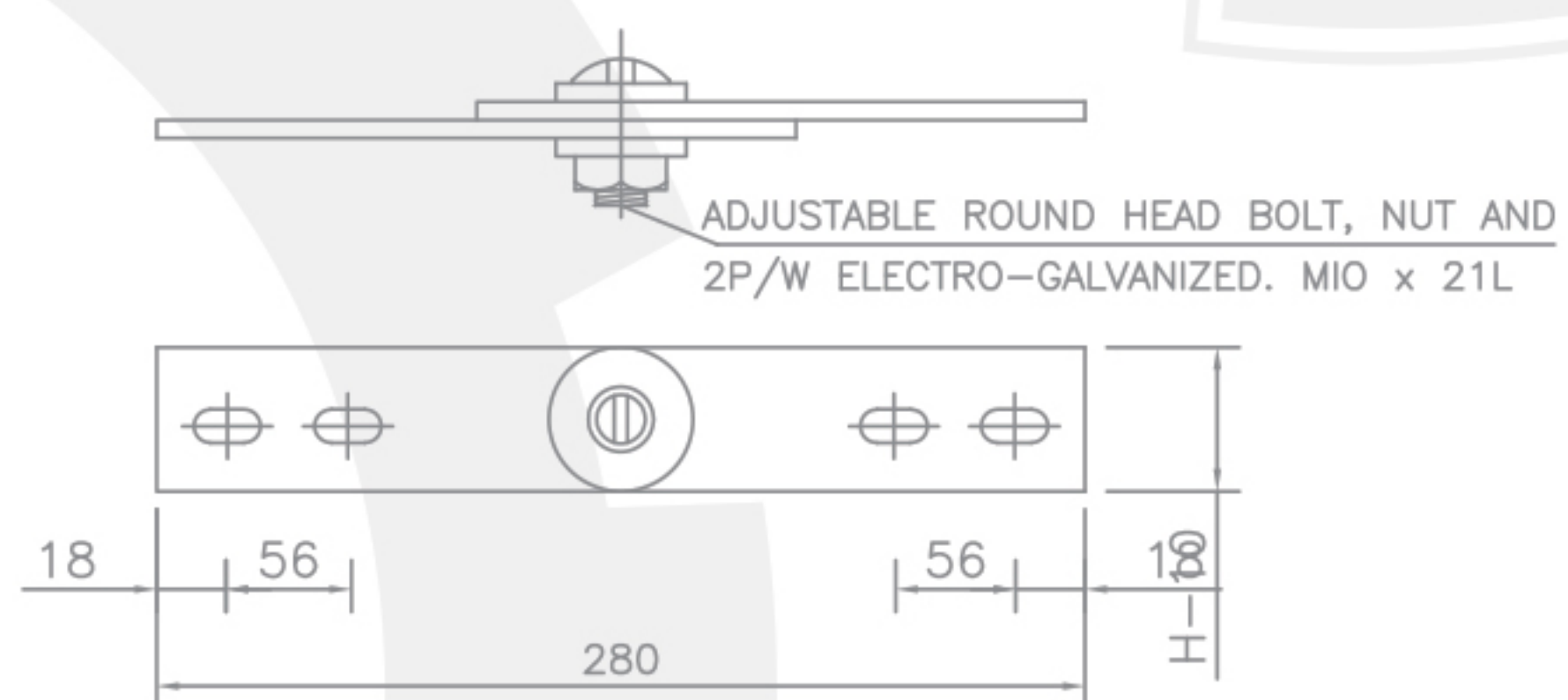

BENDING CONNECTOR(BECP)
HORIZONTAL ADJUSTABLE CONNECTOR

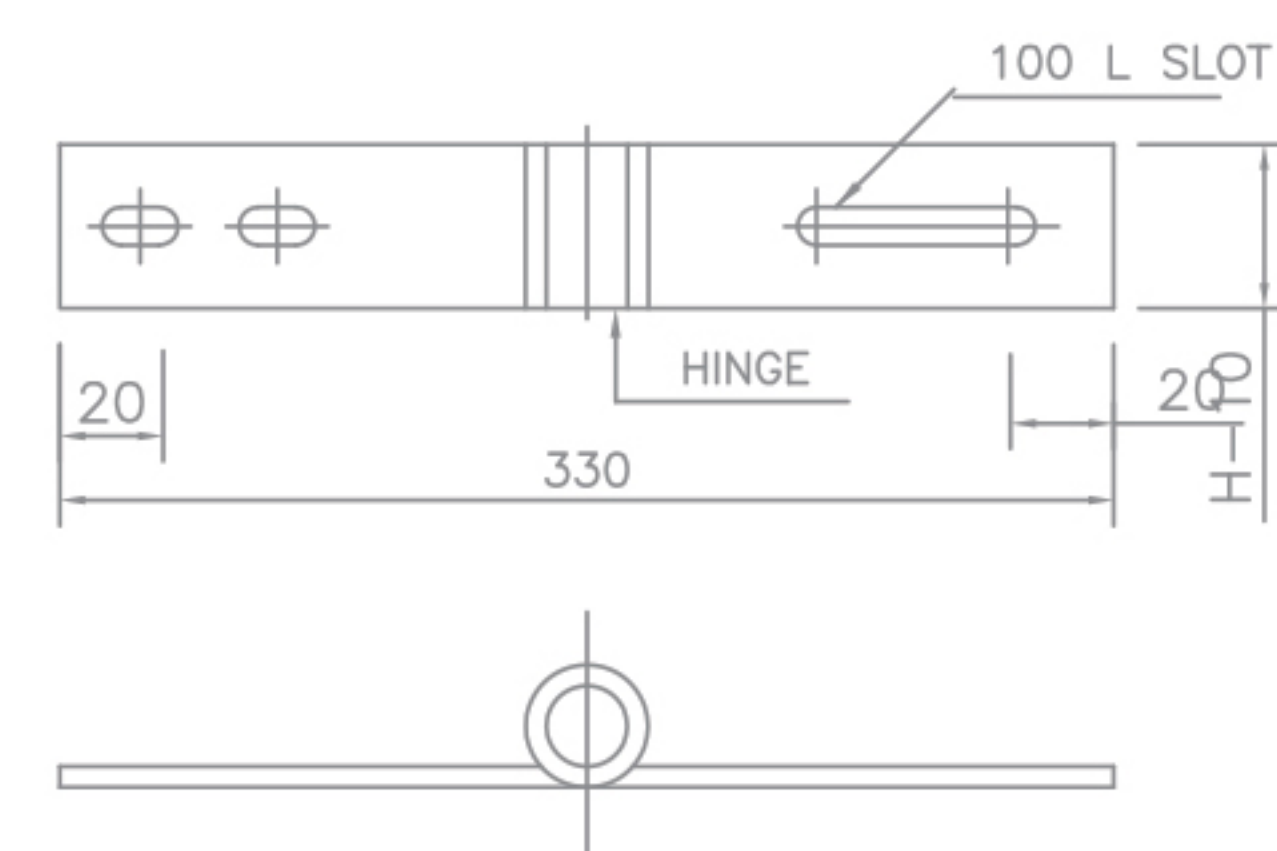

FASTENERS



Joint connector slots corresponding to side rail connection holes
H - height of side rail

All Dimensions are in mm



CABLE TRAY - PERFORATED / SOLID TYPE SUPPORT SYSTEMS

C-RAIL 1

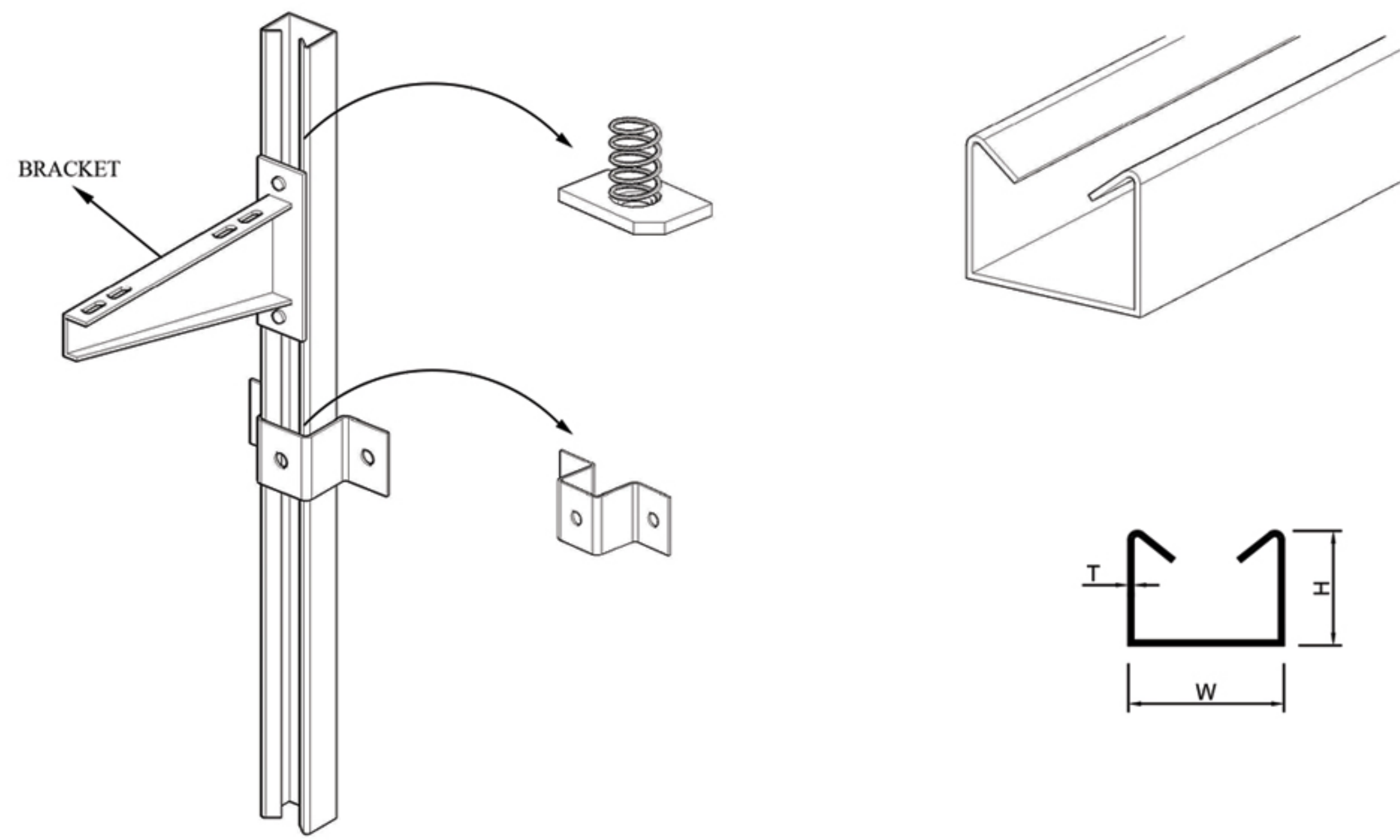

C-RAIL 2

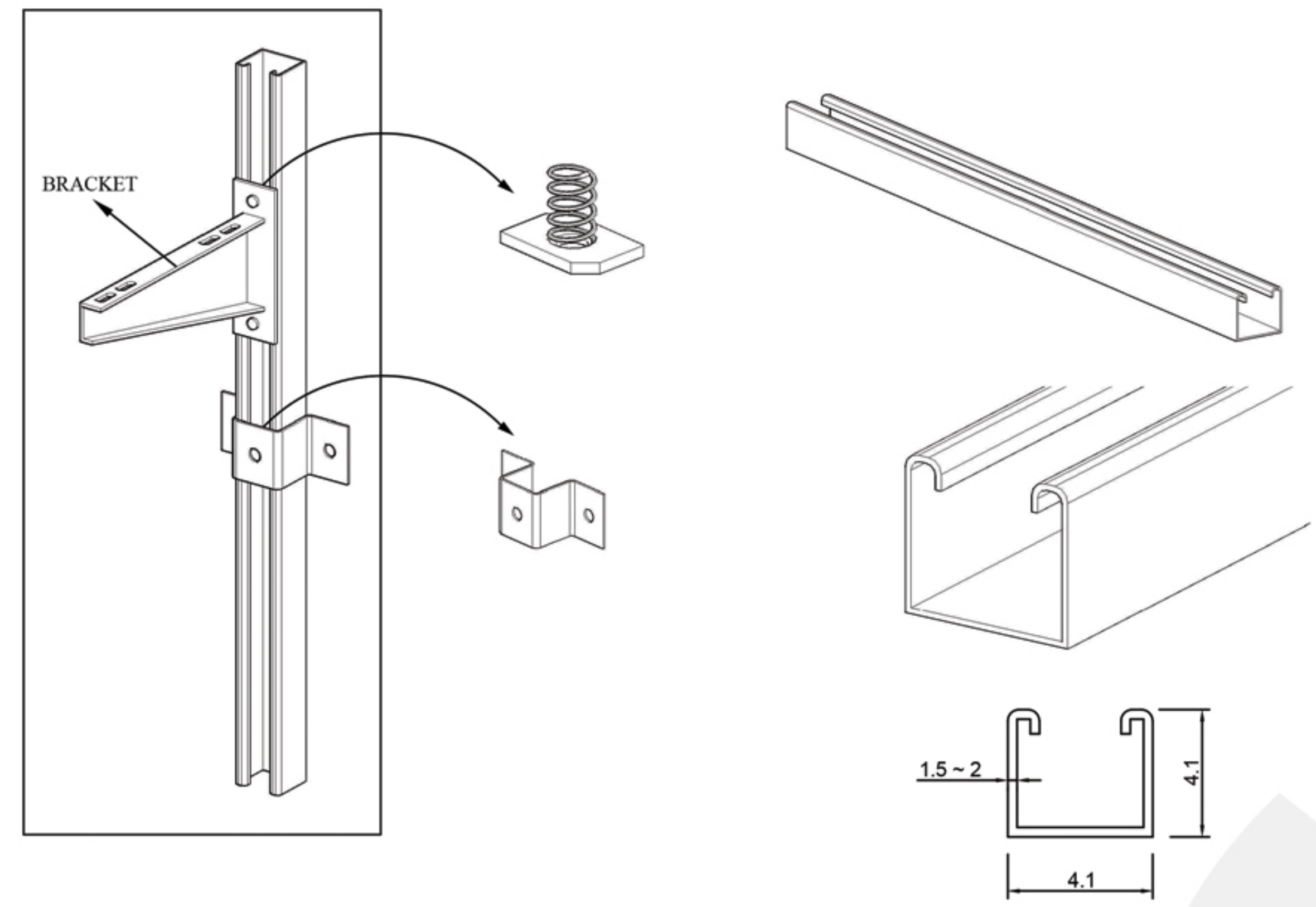

WALL BRACKET

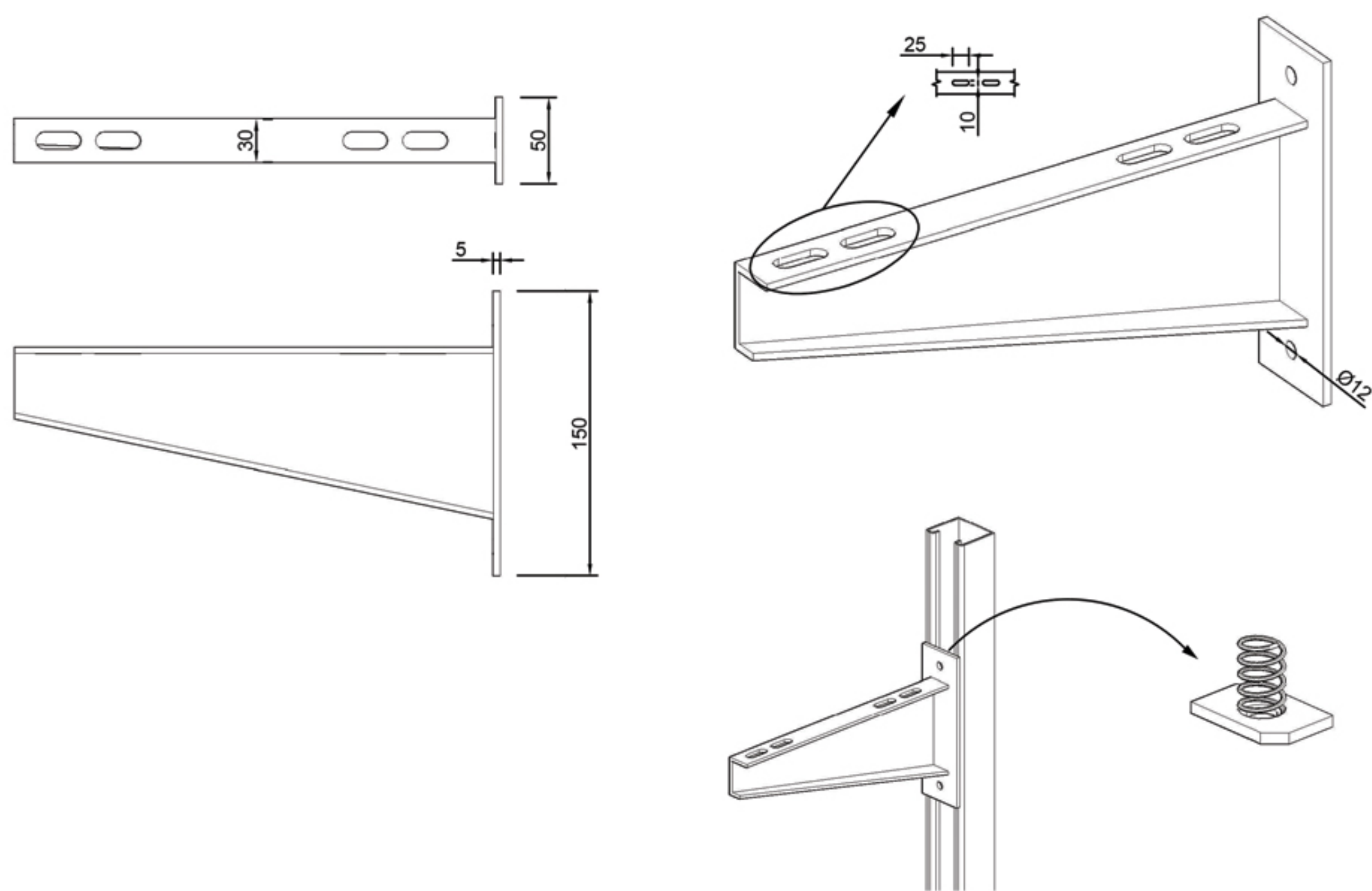

U SUPPORT

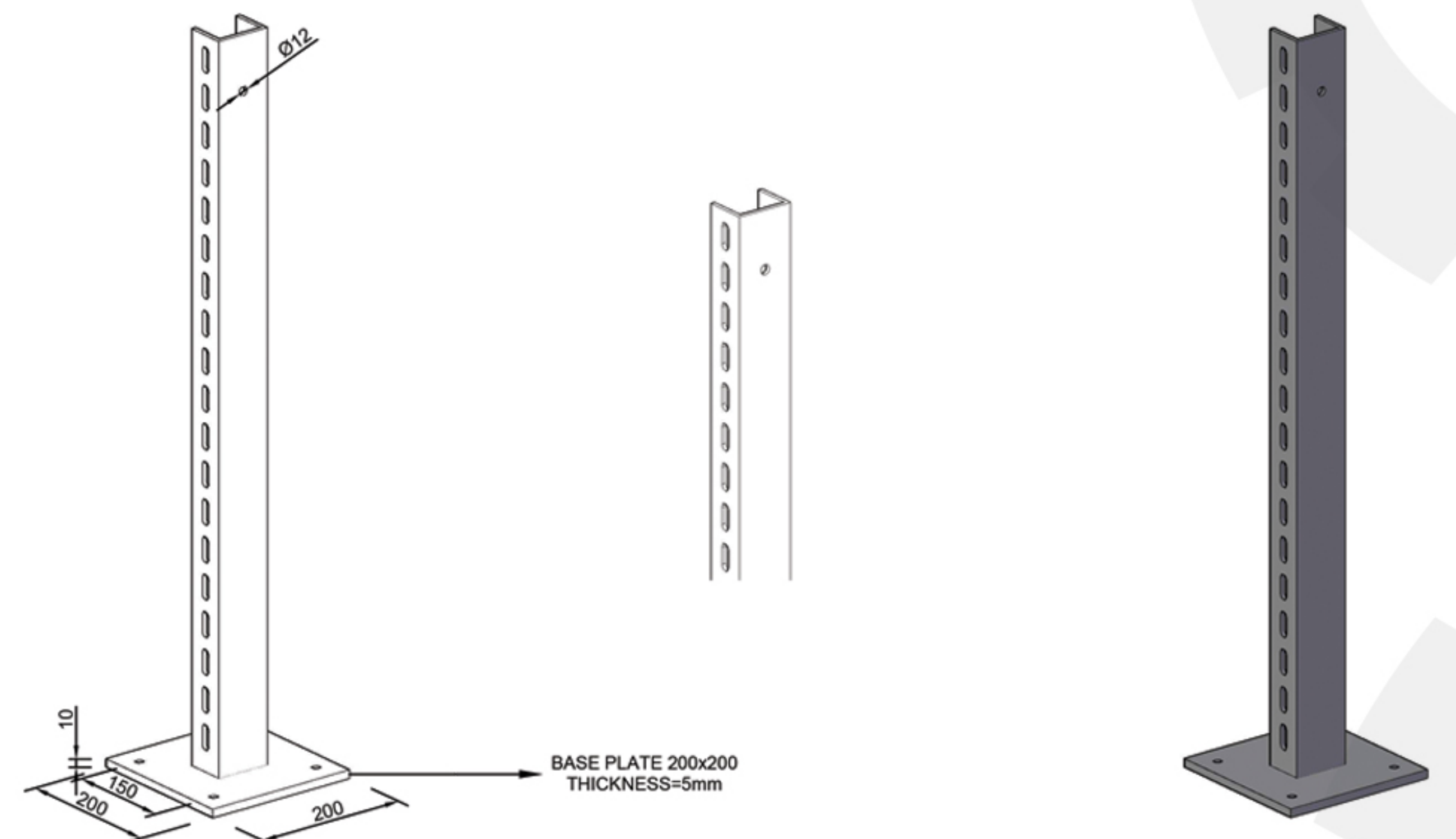

L SUPPORT

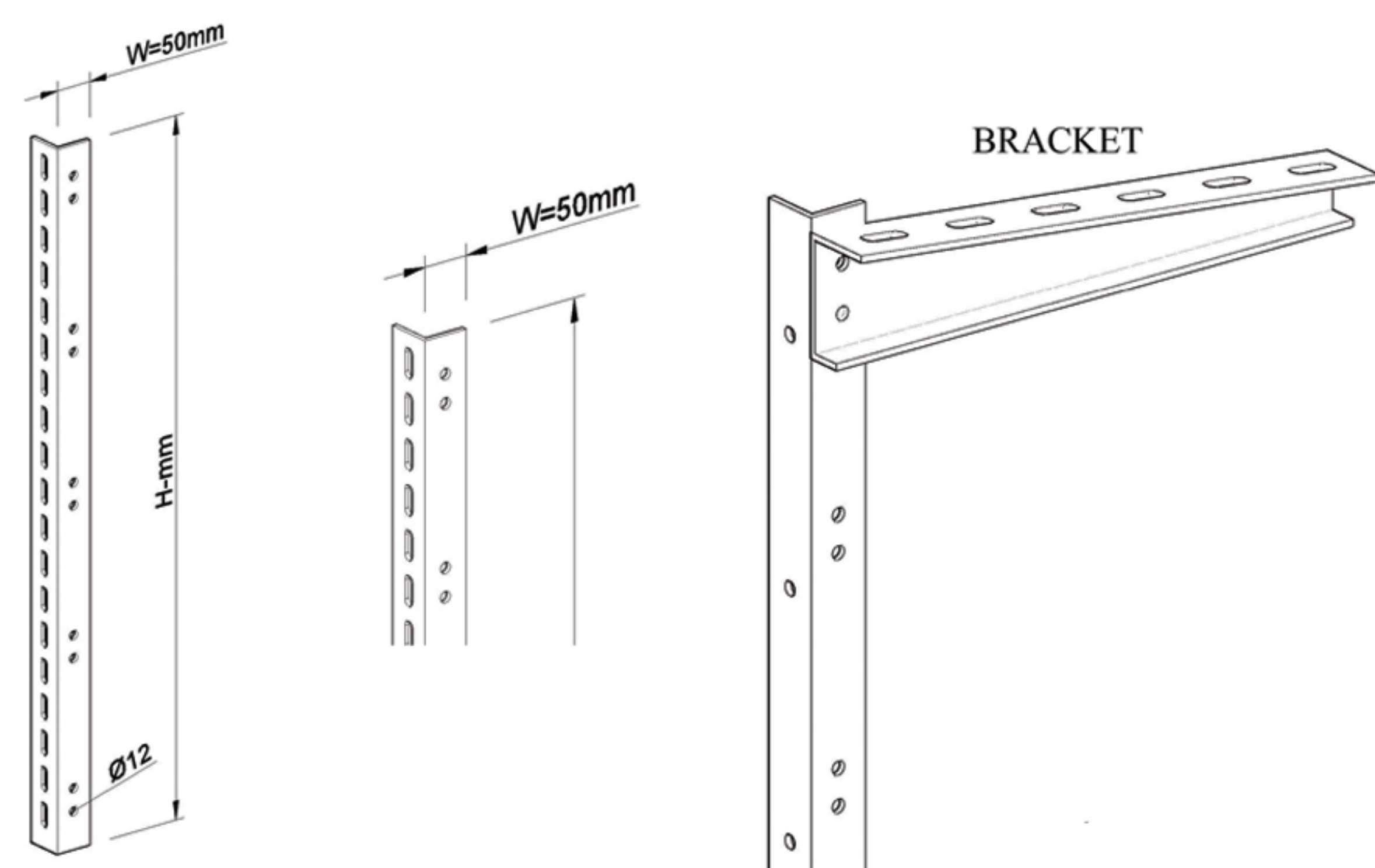

REGULATED SUPPORT

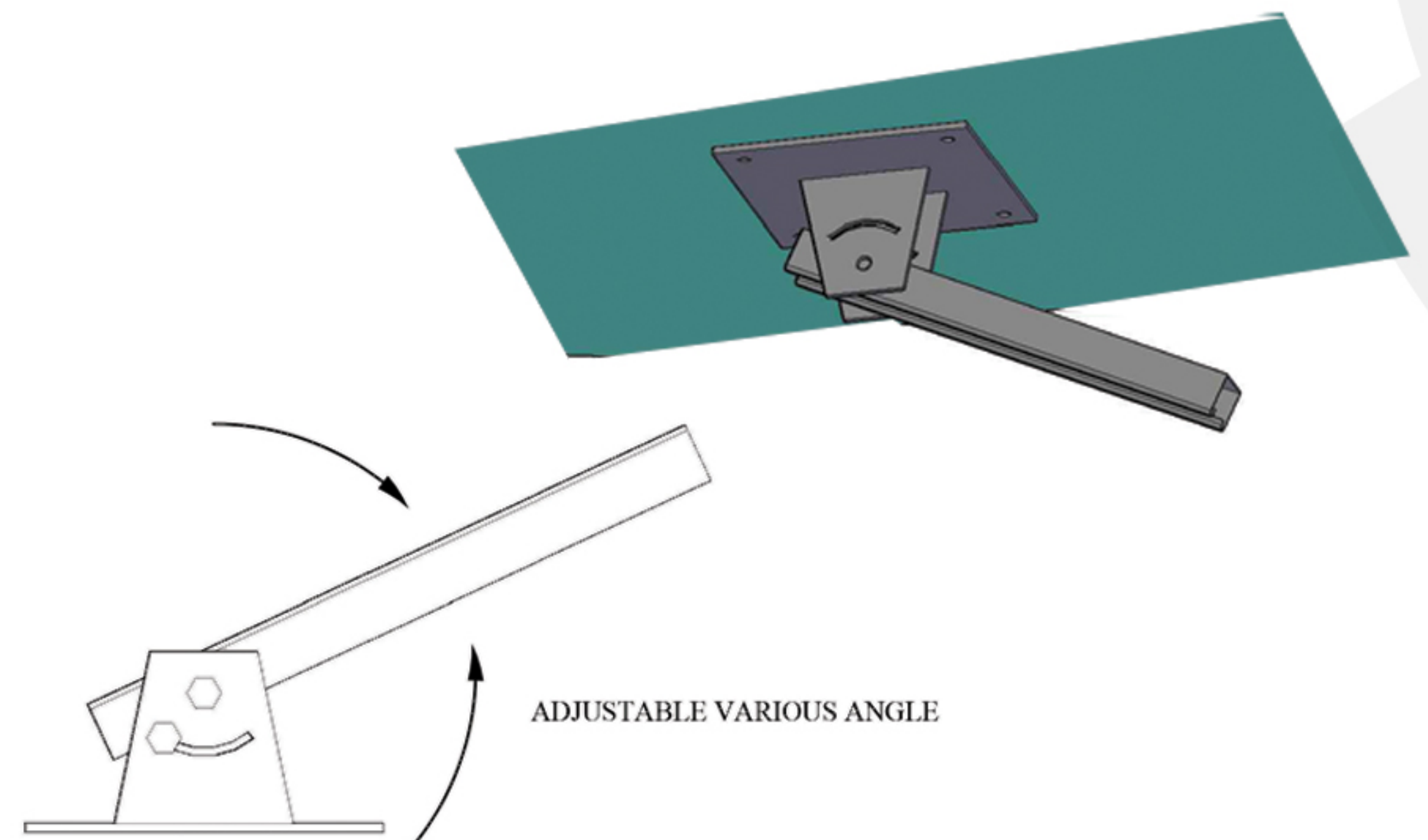



MANUFACTURING STANDARDS OF CABLE TRAYS

1.1 Materials

Cable trays shall be made of either Hot Rolled or Cold Rolled Mild Steel sheets (ASTM A36) or Pre-galvanized Steel sheets (ASTM A653) or Stainless Steel sheet.

1.2. Welding

The welding procedures used in the fabrication of all ALMEER Cable Trays and Accessories are in accordance with the latest American Welding Society Standard AWS D.1.3. The welders performing the job are qualified as per relevant AWS Code. Fanavaran Steel Cable Trays are welded by SMAW (Shield Metal Arc Welding), MIG (Metal Inert Gas) or TIG (Tungsten Inert Gas) welding process for producing smooth, clean, slag-free weldments.

1-3. Finishes

ALMEER supplies Cable Trays in five different finishes .

1. **Pre-galvanized finish:** As per ASTM A653, usually Pre-galvanized sheets are used for manufacturer of Cable Trays.
2. **Hot-Dip galvanized finish:** Cable trays fabricated from black steel sheet are Hot-Dip galvanized after fabrication in accordance with BS EN ISO 1461 or ASTM A123 "Specification for Zinc Coating (Hot dip) assembled Steel products."
3. **Painted finish:** Cable Trays fabricated from black steel sheet are sand-blasted and painted after fabrication as per clients specification.
4. **Powder Coated finish:** Cable Trays fabricated from black steel sheet are powder coated after fabrication.
5. **Stainless Steel finish:** Cable Trays are fabricated from stainless steel sheets grade 304, 316 or 316L, usually supplied in Stainless Steel '2B' finish.

2-1. Dimensions

Cable Trays

1. Lengths of Straight Sections is usually in 3.0 Mtr or 2.44 Mtr with a tolerance of plus or minus 3mm not including connectors if attached.
2. Widths - 50,75, 100, 150, 200, 300, 450, 600, 750 and 900mm plus or minus 6.0mm inside Dimension.
3. Depths - Outside depths shall be 50,75, 100, 120 and 150 mm plus or minus 3.0mm
4. Radius - 300, 450, 600 and 900mm.
5. Degree of Arc for Bends - 30, 45, 60 and 90 degrees.
6. Bottom- Perforated or Solid Type

۷- آزمون و تست های روتین

- بر روی تمامی محصولات تولید شده در مجموعه فناوران قبل از حمل و بارگیری در کارگاه تست های زیر انجام می شود:
- تست بارگذاری
 - تست های مربوط به پوشش گالوانیزه

3. Protection for Cables

The inside of cable tray systems have smooth surface without any sharp edges, burrs or projections which may cause damage to cables during installation.

4. Fittings

The design and construction for all types of Cable Tray & Fittings is based on supporting to cable trays as recommended in Cable Tray Standard NEMA VE -1

5. Applicable Codes and Standards

All equipment, material and workmanship shall comply with the requirements and latest revisions of the following standards and codes whichever is applicable,

- BSI British Standards Institute
- NEMA National Electrical Manufacturers Association
- NEC National Electrical Code of USA
- ASTM American Society for Testing and Materials
- AWS American Welding Society
- JIS Japanese Industrial Standards
- KS Korean Standards

6. Tests

Applicable tests are carried out on the fabricated samples.

The tests usually carried out are:-

- Load Test.
- Relevant Tests on Coatings.

۱- مواد اولیه

سینی کابل ها می بایست از ورق سیاه، ورق روغنی و یا ورق سفید تولید شود.

۲- جوشکاری

روش های جوشکاری مورد استفاده برای تولید تمامی سینی کابل ها و نردبان کابل و لوازم جانبی مطابق با آخرین استاندارد روز دنیا می باشد.

۳- پوشش گالوانیزه

مجموعه فناوران محصولات تولیدی خود را با چند نوع پوشش متنوع تولید می کند:

- گالوانیزه سرد مطابق با استاندارد ASTM A653.
- گالوانیزه گرم عمقی مطابق با استاندارد ASTM A123
- رنگ الکترواستاتیک کوره ای
- فولاد ضد زنگ از ورق فولادی با گرید ۳۰۴، ۳۱۶L و یا ۳۱۶L.

۴- ابعاد

طول : سینی های کابل در شاخه های ۲ و ۳ متری قابل تولید می باشد.
عرض: سینی های کابل در عرض های ۵، ۱۰، ۱۵، ۲۰، ۲۵، ۳۰، ۴۰، ۵۰، ۶۰، ۷۰، ۸۰، ۹۰ و ۱۰۰ سانتیمتری تولید می شود.
ارتفاع لبه : از ۴ الی ۱۰ سانتیمتر
تعداد خم : به صورت ۲، ۴ و ۶ خم قابل تولید می باشد.
نوع پانچ : در دو مدل بدون پانچ (ترانکینگ) و پانچ شده (پانچ موازی و پانچ متقاطع) عرضه می گردد.

۵- اتصالات و لوازم جانبی سینی کابل

طراحی و ساخت تمامی اتصالات و لوازم جانبی سینی کابل مطابق با استاندارد NEMA VE-1 می باشد.

۶- استاندارد ها

تمامی تجهیزات، قطعات و مواد اولیه مورد استفاده برای تولید سینی کابل مطابق با استاندارد های بین المللی می باشد که عبارتند از :

- AWS - BSI
- JIS - NEMA
- KS - NEC
- ASTM -



گروه صنعتی فناوران

آدرس: تهران، خیابان طالقانی، خیابان بشارت، پلاک ۱۲

تلفن: ۸۸۹۲۰۵۴۷ | ۸۸۸۹۱۸۳۴

ایمیل: info@t-fanavar.com



www.t-fanavar.com

Fanavaran Industrial Group

Add: No.12, Besharat St., Taleghani St., Tehran, IRAN

Tell: 88920547 | 88891834

E-mail: info@t-fanavar.com